



### L6C Series

Liquid-cooled submersible motors, suitable for use with 6" borehole pumps. The choice of component materials ensures optimum operating performance. Made almost entirely of stainless steel. Motor adapter and coupling dimensions to NEMA standards.

#### SPECIFICATIONS

**Power supply:** three-phase  
50 and 60 Hz

**Power:** 4 kW to 37 kW 380-415 V;  
overload protection to be provided by user and installed in the control box (see control box section)

**Maximum overall diameter of pump (cable cover included):**  
140 mm

**Maximum immersion depth:**  
250 metres

**Maximum water temperature:**  
+35°C.

**Insulation class:** F

**Protection:** IP68

**Tolerances:** +/-10%

Extractable supply cable fitted with watertight connector

Can also operate in a horizontal position provided the pump can develop an axial thrust of 250 N over the entire operating field.

#### MATERIALS

**Outer and inner sleeves, flanges:** Stainless steel

**Shaft extension:** Stainless steel

**Upper support:** Cast-iron

**Elastomers:** NBR

**Compensating diaphragm:** EPDM

**Bearings:** Carbon-graphite  
Cooling liquid: Demineralised water + antifreeze

#### APPLICATIONS

- Water supply
- Pressure boosting
- Irrigation
- Fire-fighting



For a complete list of technical information, consult [www.lowara.com](http://www.lowara.com)

*Engineered for life*



### L6C SERIES MOTORS DIMENSIONS AND WEIGHTS AT 50 Hz

4

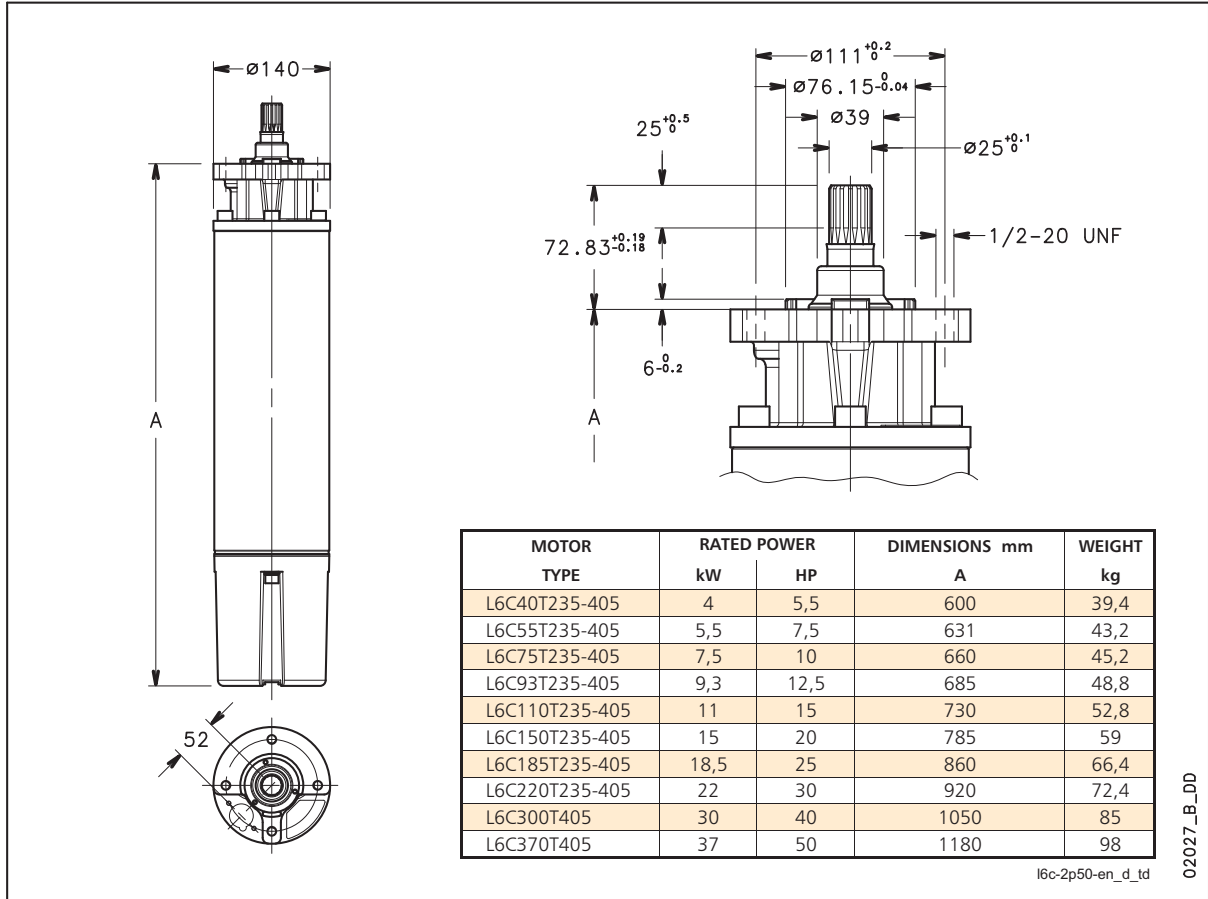



## General Catalogue

### L6C SERIES MOTORS – THREE-PHASE OPERATING CHARACTERISTICS AT 50 Hz

MOTOR TYPE	RATED POWER		RATED VOLTAGE	OPERATING CHARACTERISTICS AT RATED POWER				DIRECT START		MAX WATER TEMPERATURE °C	CABLE TYPE	
	kW	HP		RATED CURRENT A	rpm	%	cos	Ts/Tn*	Is/In		Nc x sec mm <sup>2</sup>	L m
L6C40T235	4	5,5	220	17,8	2825	75	0,8	1,7	3,9	35	4x4	4
			230	18,4	2845	74	0,75	1,7	3,9			
			240	19,1	2860	74	0,7	1,7	3,8			
L6C55T235	5,5	7,5	220	24,1	2820	77	0,8	1,8	3,8	35	4x4	4
			230	24,2	2845	76	0,75	1,8	3,8			
			240	25,3	2860	76	0,71	1,8	3,6			
L6C75T235	7,5	10	220	30,5	2820	78	0,82	2	3,9	35	4x4	4
			230	31,2	2840	77	0,78	2	3,9			
			240	31,7	2850	77	0,73	2	4			
L6C93T235	9,3	12,5	220	37,6	2820	78	0,82	2,1	3,8	35	4x6	4
			230	38,1	2840	79	0,8	2,1	3,9			
			240	39,5	2850	78	0,79	2,15	3,9			
L6C110T235	11	15	220	43,3	2815	77	0,87	2,1	4,5	35	4x6	4
			230	44,2	2840	78	0,82	2,1	4,5			
			240	45,0	2845	77	0,79	2,15	4,5			
L6C150T235	15	20	220	58,0	2810	80	0,84	2,2	4,1	35	4x8	4
			230	57,9	2840	81	0,8	2,2	4,1			
			240	59,2	2850	81	0,76	2,25	4,1			
L6C185T235	18,5	25	220	70,1	2820	81	0,83	2,3	4,3	35	4x8	4
			230	71,0	2845	82	0,8	2,3	4,3			
			240	72,7	2855	82	0,73	2,35	4,3			
L6C220T235	22	30	220	82,3	2810	81	0,88	2,3	4	35	4x8	4
			230	81,4	2825	82	0,84	2,3	4,1			
			240	82,3	2835	82	0,8	2,35	4,2			
L6C40T405	4	5,5	380	10,3	2825	75	0,8	1,7	3,9	35	4x4	4
			400	10,6	2845	74	0,75	1,7	3,9			
			415	11	2860	74	0,7	1,7	3,8			
L6C55T405	5,5	7,5	380	13,9	2820	77	0,8	1,8	3,8	35	4x4	4
			400	14	2845	76	0,75	1,8	3,8			
			415	14,6	2860	76	0,71	1,8	3,6			
L6C75T405	7,5	10	380	17,6	2820	78	0,82	2	3,9	35	4x4	4
			400	18	2840	77	0,78	2	3,9			
			415	18,3	2850	77	0,73	2	4			
L6C93T405	9,3	12,5	380	21,7	2820	78	0,82	2,1	3,8	35	4x4	4
			400	22	2840	79	0,8	2,1	3,9			
			415	22,8	2850	78	0,79	2,15	3,9			
L6C110T405	11	15	380	25	2815	77	0,87	2,1	4,5	35	4x4	4
			400	25,5	2840	78	0,82	2,1	4,5			
			415	26	2845	77	0,79	2,15	4,5			
L6C150T405	15	20	380	33,5	2810	80	0,84	2,2	4,1	35	4x4	4
			400	33,4	2840	81	0,8	2,2	4,1			
			415	34,2	2850	81	0,76	2,25	4,1			
L6C185T405	18,5	25	380	40,5	2820	81	0,83	2,3	4,3	35	4x6	4
			400	41	2845	82	0,8	2,3	4,3			
			415	42	2855	82	0,73	2,35	4,3			
L6C220T405	22	30	380	47,5	2810	81	0,88	2,3	4	35	4x6	4
			400	47	2825	82	0,84	2,3	4,1			
			415	47,5	2835	82	0,8	2,35	4,2			
L6C300T405	30	40	380	63	2810	82	0,89	2,4	4	35	4x8	4
			400	61,5	2830	82	0,85	2,4	4,1			
			415	63,5	2840	81	0,8	2,45	3,9			
L6C370T405	37	50	380	79,5	2820	82	0,87	2	3,7	35	4x8	4
			400	79,3	2830	81	0,84	2,2	3,9			
			415	80	2840	81	0,8	2,3	4			

\* Ts/Tn = ratio between starting torque and nominal torque.

l6c-2p50-en\_f\_te