

SH SERIES

CENTRIFUGAL PUMPS MANUFACTURED IN AISI 316 STAINLESS STEEL IN COMPLIANCE WITH EN 733 - (ex DIN 24255)

Laser-technology welded centrifugal pumps.
Designed to handle hot, cold and moderately aggressive liquids.

APPLICATIONS

- Water circulation and transfer in the civil, industrial and agricultural markets.
- Industrial washing.
- Pressure boosting.
- Hot and cold water circulation for heating and conditioning systems.

AVAILABLE MODELS

- **SHE** close-coupled with special motor shaft extension.
- **SHS** with stub shaft and standard motor.
- **SHF** with flexible coupling, base and standard motor in compliance with EN 733 - (ex DIN 24255).
- **SSH** 25-125, 160, 200, 250 on request.

SPECIFICATIONS

- **Maximum delivery** up to **240 m³/h.**
- **Maximum head** up to **110 m.**
- 316L stainless steel, laser-welded impeller (up to 65-160 size) and pump body.
- **AISI 316L** stainless steel wear rings.
- **Port nominal diameter** up to **DN 80.**
- **Impeller nominal diameter** up to **250 mm.**
- 2- and 4-pole three-phase motors.
- 50 and 60 Hz frequencies.
- Counterflanges available on request.
- IP55 protection.
- Class F insulation.
- **Maximum operating pressure: 12 bar (PN12).**
- Pumped **liquid temperature -10°C to +110°C.**
- **Versions with HYDROVAR frequency converter (variable speed) are available on request.**



TABLE OF MATERIALS

PART	MATERIAL
Pump body, Seal housing, Impeller	STAINLESS STEEL
Wear ring	AISI 316L - DIN 1.4404
Counterwear ring	
Adapter	ALUMINIUM OR DIN GG20 CAST IRON
Mechanical seal	CERAMIC/CARBON/FPM
O-Ring	FPM
Fill/drain plugs	STAINLESS STEEL AISI 316L-DIN 1.4404
Shaft (SHE - SHF), Coupling (SHS)	STAINLESS STEEL AISI 316 - DIN 1.4401
Support body (SHF)	DIN GG20 CAST IRON

IDENTIFICATION CODE

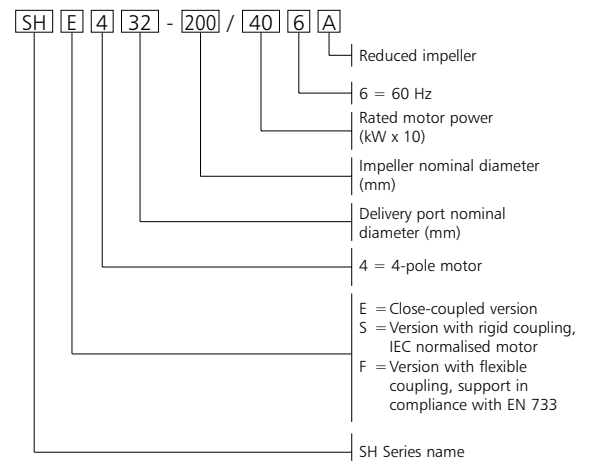

ELECTRICAL SPECIFICATIONS MOTORS WITH EXTENDED SHAFT FOR SHE SERIES

SINGLE-PHASE 50 Hz 2 POLES MOTORS

MOTOR TYPE			INPUT CURRENT In (A) 220-240 V	CAPACITOR		DATA FOR 230 V 50 Hz					
kW	IEC SIZE *	CONSTRUCTION DESIGN		μ F	V	rpm	Is / In	n %	cos ϕ	Cn Nm	Cs/Cn
1.1	90R	B14	7.07-6.81	30	450	2800	3.80	73.8	0.95	3.75	0.47

* R = Reduced size of motor casing as compared to shaft extension and flange.

she-motm-2p50_a_te

THREE-PHASE 50 Hz 2 POLES MOTORS

MOTOR TYPE			INPUT CURRENT In (A)				DATA FOR 400 V 50 Hz					
kW	IEC SIZE *	CONSTRUCTION DESIGN	220-240 V		380-415 V		rpm	Is / In	n %	cos ϕ	Cn Nm	Cs/Cn
			Δ	Y	Δ	Y						
0.75	90R	B14	3.72	2.15	-	-	2915	8.23	77.7	0.65	2.45	5.20
1.1	90R	B14	4.52	2.61	-	-	2875	6.78	78.9	0.77	3.65	3.49
1.5	90R	B14	5.98	3.45	-	-	2875	7.04	80.1	0.78	4.98	3.83
2.2	90R	B14	8.71	5.03	-	-	2860	7.32	81.1	0.78	7.34	4.12
3	90	B14	10.8	6.22	-	-	2845	6.81	80.4	0.87	10.1	3.00
4	112R	B14	-	-	8.14	4.70	2900	7.86	83.5	0.85	13.2	2.86
5.5	112	B14	-	-	11.0	6.35	2910	7.71	84.5	0.85	18.0	2.66
7.5	112	B14	-	-	14.6	8.43	2910	7.62	87.2	0.85	24.6	3.03
9.2	132	B14	-	-	17.5	10.1	2925	8.72	86.3	0.88	30.0	3.33
11	132	B14	-	-	21.2	12.2	2925	8.75	88.8	0.84	35.9	3.66
15	160	B34	-	-	28.6	16.5	2940	8.56	85.3	0.89	48.7	3.10
18.5	160	B34	-	-	34.2	19.7	2945	8.80	87.3	0.90	60.0	4.06
22	160	B34	-	-	40.3	23.3	2945	8.61	89.5	0.88	71.2	4.79

* R = Reduced size of motor casing as compared to shaft extension and flange.

she-mott-2p50_a_te

THREE-PHASE 50 Hz 4 POLES MOTORS

MOTOR TYPE			INPUT CURRENT In (A)				DATA FOR 400 V 50 Hz					
kW	IEC SIZE *	CONSTRUCTION DESIGN	220-240 V		380-415 V		rpm	Is / In	n %	cos ϕ	Cn Nm	Cs/Cn
			Δ	Y	Δ	Y						
0.25	71	B5	1.71	0.99	-	-	1390	3.58	62.0	0.59	1.71	3.16
0.37	71	B5	2.53	1.46	-	-	1370	3.39	61.4	0.60	2.57	3.40
0.55	90R	B14	3.03	1.75	-	-	1390	3.95	68.2	0.67	3.77	2.45
0.75	90R	B5	4.04	2.33	-	-	1395	4.06	70.1	0.66	5.13	2.73
1.1	90	B5	4.35	2.51	-	-	1415	4.65	78.0	0.81	7.42	2.15
1.5	90	B5	5.85	3.38	-	-	1420	4.99	79.9	0.80	10.1	2.26
2.2	100	B5	8.28	4.78	-	-	1410	5.53	81.4	0.82	14.9	2.52
3	100	B5	11.0	6.37	-	-	1425	6.03	82.5	0.82	20.1	2.53
4	112	B5	-	-	8.38	4.84	1440	5.81	84.8	0.81	26.5	2.50
5.5	132	B14	-	-	11.3	6.52	1445	5.98	85.8	0.82	36.3	2.60
7.5	132	B14	-	-	15.2	8.78	1450	6.70	88.1	0.81	49.3	3.17
9.2	132	B14	-	-	19	11.0	1445	5.63	87.9	0.80	60.7	2.80

* R = Reduced size of motor casing as compared to shaft extension and flange.

she-mott-4p50_a_te



ELECTRICAL SPECIFICATIONS STANDARD MOTORS FOR SHS - SHF SERIES

THREE-PHASE 50 Hz 2 POLES MOTORS

MOTOR TYPE				INPUT CURRENT				DATA FOR 400 V 50 Hz					
kW	IEC SIZE *	CONSTRUCTION		In (A)				rpm	Is / In	n %	cosφ	Cn Nm	Cs/Cn
		SHS	SHF	Δ 220-240 V	Y 380-415 V	Δ 380-415 V	Y 660-690 V						
0.75	80R	B5	-	3.50	2.02	-	-	2855	5.81	74.3	0.72	2.51	3.76
0.75	80	-	B3	3.72	2.15	-	-	2915	8.23	77.7	0.65	2.45	5.20
1.1	80	B5	B3	4.52	2.61	-	-	2875	6.78	78.9	0.77	3.65	3.49
1.5	90R	B5	-	5.98	3.45	-	-	2875	7.04	80.1	0.78	4.98	3.83
1.5	90	-	B3	5.66	3.27	-	-	2875	6.40	76.5	0.87	4.98	2.71
2.2	90R	B5	-	8.71	5.03	-	-	2860	7.32	81.1	0.78	7.34	4.12
2.2	90	-	B3	8.02	4.63	-	-	2870	6.94	80.0	0.86	7.32	2.85
3	100R	B5	-	10.8	6.22	-	-	2845	6.81	80.4	0.87	10.1	3.00
3	100	-	B3	10.6	6.10	-	-	2895	6.53	83.6	0.85	9.89	3.34
4	112R	B5	-	-	-	8.14	4.70	2900	7.86	83.5	0.85	13.2	2.86
4	112	-	B3	-	-	8.21	4.74	2915	7.41	82.2	0.86	13.1	2.58
5.5	132R	B5	-	-	-	11.0	6.35	2910	7.71	84.5	0.85	18.0	2.66
5.5	132	-	B3	-	-	10.7	6.18	2905	6.53	84.4	0.88	18.1	2.39
7.5	132R	B5	-	-	-	14.6	8.43	2910	7.62	87.2	0.85	24.6	3.03
7.5	132	-	B3	-	-	14.4	8.31	2915	7.37	85.8	0.88	24.6	2.69
11	160	B35	B3	-	-	21.6	12.5	2925	6.83	82.4	0.89	35.9	2.97
15	160	B35	B3	-	-	28.6	16.5	2940	8.56	85.3	0.89	48.7	3.10
18.5	160	B35	B3	-	-	34.2	19.7	2945	8.80	87.3	0.90	60.0	4.06
22	180R	B35	-	-	-	40.3	23.3	2945	8.61	89.5	0.88	71.2	4.79
22	180	-	B3	-	-	42.0	24.2	2930	7.10	90.0	0.84	71.0	2.50
30	200	B35	B3	-	-	55.0	31.8	2945	6.80	90.5	0.87	97.0	2.40
37	200	B35	B3	-	-	67.0	38.7	2940	7.20	91.5	0.87	120	2.50
45	225	-	B3	-	-	81.0	46.8	2955	6.70	91.3	0.88	145	2.40
55	250	-	B3	-	-	98.0	56.6	2960	6.70	92.1	0.88	177	2.40
75	280	-	B3	-	-	134	77.4	2965	6.80	92.8	0.87	241	2.30

* R = Reduced size of motor casing as compared to shaft extension and flange.

shs-shf-mott-2p50_a_te

ELECTRICAL SPECIFICATIONS STANDARD MOTORS FOR SHS - SHF SERIES

THREE-PHASE 50 Hz 4 POLES MOTORS

MOTOR TYPE				INPUT CURRENT				DATA FOR 400 V 50 Hz					
kW	IEC SIZE *	CONSTRUCTION		In (A)				rpm	Is / In	n %	cosφ	Cn Nm	Cs/Cn
		SHS	SHF	Δ	Y	Δ	Y						
				220-240 V	380-415 V	380-415 V	660-690 V						
0.25	71	-	B3	1.71	0.99	-	-	1390	3.58	62.0	0.59	1.71	3.16
0.37	71	-	B3	2.53	1.46	-	-	1370	3.39	61.4	0.60	2.57	3.40
0.55	80	B5	B3	3.03	1.75	-	-	1390	3.95	68.2	0.67	3.77	2.45
0.75	80	B5	B3	4.04	2.33	-	-	1395	4.06	70.1	0.66	5.13	2.73
1.1	90	B5	B3	4.35	2.51	-	-	1415	4.65	78.0	0.81	7.42	2.15
1.5	90	B5	B3	5.85	3.38	-	-	1420	4.99	79.9	0.8	10.1	2.26
2.2	100	B5	B3	8.28	4.78	-	-	1410	5.53	81.4	0.82	14.9	2.52
3	100	B5	B3	11.0	6.37	-	-	1425	6.03	82.5	0.82	20.1	2.53
4	112	B5	B3	-	-	8.38	4.84	1440	5.81	84.8	0.81	26.5	2.50
5.5	132	B5	B3	-	-	11.3	6.52	1445	5.98	85.8	0.82	36.3	2.60
7.5	132	B5	B3	-	-	15.2	8.78	1450	6.70	88.1	0.81	49.3	3.17
9.2	132	B5	B3	-	-	19.0	11.0	1445	5.63	87.9	0.80	60.7	2.80

* R = Reduced size of motor casing as compared to shaft extension and flange.

shs-shf-mott-4p50_a_te



SHE - SHS - SHF SERIES

HYDRAULIC PERFORMANCE TABLE at 2900 rpm 50 Hz, 2 POLES

PUMP TYPE	POWER		Q = DELIVERY																				
			H = TOTAL HEAD METERS COLUMN OF WATER																				
			l/min	0	100	150	200	250	300	400	500	600	700	800	1000	1200	1400	1600	1800	2000	2500	3000	3500
		m ³ /h	0	6	9	12	15	18	24	30	36	42	48	60	72	84	96	108	120	150	180	210	228
		kW	HP																				
32-125/07 *	0,75	1	16,6	15,6	14,4	13	11,3	9,5															
32-125/11 *	1,1	1,5	21,6	20,6	19,4	18	16	14	9,8														
32-160/15 *	1,5	2	26,7	25	23,5	21,5	19,5	17	11,7														
32-160/22 *	2,2	3	35	33,6	32,5	31	29	26,5	21														
32-200/30 *	3	4	43,7	40,7	38,5	36	33	30	21														
32-200/40 *	4	5,5	53,5	51	49	47	44	41	32,3														
32-250/55 *	5,5	7,5	58,6	55,5	53,4	51	48	44,5	36,8														
32-250/75 *	7,5	10	74	71	68,9	66	63	60	52														
32-250/110*	11	15	86	82,5	80,1	77,5	74,3	71	63														
40-125/11	1,1	1,5	15,1				13,5	12,8	11,3	9,5	7,5												
40-125/15	1,5	2	18,7				17	16,5	14,8	13	10,7	8,2											
40-125/22	2,2	3	24,2				23	22,2	20,5	18,3	15,8	13,2											
40-160/30	3	4	32,2				30,5	29,5	27	24	20,8	17											
40-160/40	4	5,5	38				36,5	35,5	33	30	26,5	22,8	18,5										
40-200/55	5,5	7,5	49,1				47,5	46,4	43,5	40,5	36	31	25										
40-200/75	7,5	10	58,2				56	55,1	52,5	49	45	40	34,4										
40-250/**	11	15	65				63	62	60	56	52	44,6											
40-250/110	11	15	75				72	71	69	66	61	55											
40-250/150	15	20	88				85	84	82	78	74	69	63										
50-125/22	2,2	3	17,2							15,5	14,6	13,6	12,3	9,5	6,5								
50-125/30	3	4	21,7							20	18,8	17,6	16,4	13,5	10,5								
50-125/40	4	5,5	25,7							24	23,3	22,2	21	18	15	12							
50-160/55	5,5	7,5	34,1							32	30,6	29	27,6	24	19,9	14,7							
50-160/75	7,5	10	40,8							38,5	37,5	36	34,7	31,2	27	21,8							
50-200/**	11	15	53							49,5	47,5	45	42,8	37	29,8	20,7							
50-200/110	11	15	60,1							57	55	53	50,3	44,4	37,4	28,4							
50-250/150	15	20	70							68	67	65	63	58	51								
50-250/185	18,5	25	80							76	75	73	71	66	60								
50-250/220	22	30	89							86	85	83	81	76	69	61							
65-160/40	4	5,5	19,6										16,8	15,2	13,5	11,7	9,7	7,6					
65-160/55	5,5	10	24,2										21,4	19,8	18	16	14	11,8					
65-160/75	7,5	5,5	28,2										26	24,5	23	21	19	16,9	14,5				
65-160/**	11	15	38,2										35,4	33	30	27	23,7	20					
65-160/110	11	15	42,9										40,8	38,5	35,5	32,5	29	25,5	21,4				
65-200/150	15	20	53										50	47,5	44,5	40,5	36,5	32					
65-200/185	18,5	25	60										57,5	55	52	48,7	44,7	40	35,4				
65-200/220	22	30	68										65,5	63	60	57	53,5	49	41,8				
65-250/300	30	40	84										83	81,7	80	77	73	69	64				
65-250/370	37	50	97										97	95,3	93	90	86	82	78				
80-160/110	11	15	33												31,9	30,6	29,2	27,5	25,6	20,5	14,5		
80-160/150	15	20	39,6												38,8	37,6	36,3	34,5	32,8	27,5	21,5	15	
80-160/185	18,5	25	46,5												45,7	44,7	43	41,5	40	35	29	22,5	19,5
80-200/220	22	30	52													50,5	49	47,5	45,8	41	35	28,5	
80-200/300	30	40	62													62	60,5	59	57,5	52	46,5	39,5	35,1
80-200/370	37	50	70													70	69	68	66	61	55,5	49	44,4
80-250/450***	45	61	82													81	80	78	76	70	63	54	
80-250/550***	55	75	94													94	93	91	89	83	77	68	
80-250/750***	75	100	110													111	109	108	106	101	94	86	80

* DN 25 available with the same performance of DN 32
 ** /92 in the SHE version
 /110 in the SHS-SHF version
 *** F version available only

SHS

SHE - SHS - SHF SERIES HYDRAULIC PERFORMANCE TABLE at 1450 rpm 50 Hz, 4 POLES

PUMP TYPE	POWER		Q = DELIVERY																				
			H = TOTAL HEAD METERS COLUMN OF WATER																				
			l/min	0	50	75	100	125	150	175	200	250	300	400	500	600	700	800	1000	1200	1500	1800	2200
		m³/h	0	3	4,5	6	7,5	9	10,5	12	15	18	24	30	36	42	48	60	72	90	108	132	
		kW	HP																				
32-125/02A*	0,25	0,33	4,4	4,1	3,9	3,6	3,2	2,7	2,2	1,6													
32-125/02 *	0,5	0,33	5,5	5,2	5	4,7	4,3	3,8	3,3	2,7													
32-160/02 *	0,25	0,33	6,9	6,3	5,9	5,4	4,9	4,4	3,7	2,9													
32-160/03 *	0,37	0,5	8,6	8,2	7,8	7,4	6,9	6,4	5,8	5,2	3,6												
32-200/03 *	0,37	0,5	10,8	10	9,4	8,7	7,9	7	6,1	5,1													
32-200/05 *	0,55	0,75	13,2	12,5	12	11,4	10,6	9,8	8,8	7,8	5,4												
32-250/07 *	0,75	1	14,5	13,6	13	12,3	11,6	10,8	9,9	8,9	6,5												
32-250/11 *	1,1	1,5	18,4	17,5	16,8	16,1	15,3	14,4	13,5	12,5	10,2												
32-250/15 *	1,5	2	21,3	20,3	19,7	19	18,2	17,4	16,3	15,2	12,8												
40-125/02A	0,25	0,33	4				3,6	3,5	3,3	3,1	2,7	2,1											
40-125/02	0,25	0,33	5,4				5	4,8	4,6	4,4	3,9	3,3	2										
40-125/03	0,37	0,5	6,3				5,9	5,7	5,5	5,2	4,7	4	2,7										
40-160/03	0,37	0,5	8				7,4	7,2	6,9	6,6	5,9	5,1	3,1										
40-160/05	0,55	0,75	9,2				8,7	8,5	8,2	7,9	7,2	6,4	4,4										
40-200/07	0,75	1	11,9				11,5	11,2	10,8	10,5	9,7	8,6	5,8										
40-200/11	1,1	1,5	14,2				13,5	13,3	13	12,7	11,8	10,8	8										
40-250/11	1,1	1,5	15,6				14,9	14,6	14,3	14	13	11,9											
40-250/15	1,5	2	18,1				17,3	17	16,7	16,4	15,5	14,5	11,4										
40-250/22	2,2	3	21,5				20,7	20,3	20	19,7	18,8	17,7	14,8										
50-125/03A	0,37	0,5	4,4							4,2	4	3,8	3,3	2,7	2								
50-125/03	0,37	0,5	5,4							5	4,8	4,6	4	3,3	2,6	1,8							
50-125/05	0,55	0,75	6,4							6	5,8	5,6	5	4,3	3,6	2,8							
50-160/07	0,75	1	8,2							7,8	7,6	7,3	6,7	5,9	4,9	3,8							
50-160/11	1,1	1,5	9,9							9,3	9,1	8,8	8,2	7,4	6,6	5,4							
50-200/11	1,1	1,5	12,8							12,1	11,7	11,2	10	8,6	6,8	4,8							
50-200/15	1,5	2	14,7							13,9	13,6	13	11,8	10,4	8,7	6,6							
50-250/22A	2,2	3	17,5							16,8	16,4	16	15	13,8	12	9,7							
50-250/22	2,2	3	19,4							18,5	18,2	17,8	16,8	15,5	13,8	11,6							
50-250/30	3	4	21,9							21,3	20,9	20,5	19,6	18,4	16,8	14,7							
65-160/05	0,55	0,75	5,4										4,2	3,7	3,3	2,7	2,2						
65-160/07	0,75	1	6,4										5,3	4,8	4,4	3,8	3,4						
65-160/11A	1,1	1,5	7,6										6,5	6,1	5,7	5,1	4,6	3,4					
65-160/11	1,1	1,5	9,4										8,5	7,9	7,2	6,3	5,5	3,4					
65-160/15	1,5	2	10,6										9,7	9,2	8,5	7,7	6,9	4,9					
65-200/15	1,5	2	11,8										11	10,2	9,4	8,4	7,4	5,1					
65-200/22	2,2	3	14,4										13,5	12,8	12	11	10	7,9					
65-200/30	3	4	17,5										16,8	16,3	15,6	14,7	13,8	11,7	9,3				
65-250/40	4	5,5	20,4										20	19,5	18,9	18	17,3	15,1	12				
65-250/55	5,5	7,5	23,7										23,7	23,2	22,6	22	21	19	16,3				
80-160/15	1,5	2	8											7,6	7,2	6,8	6	5,1	3,6				
80-160/22A	2,2	2	9,4											9	8,7	8,3	7,5	6,6	5	3,2			
80-160/22	2,2	3	10,8											10,4	10,1	9,7	9	8	6,4	4,5			
80-200/30	3	4	12,3											12,5	12,2	11,8	10,8	9,8	8	6,1			
80-200/40	4	5,5	15,4											15,8	15,5	15,2	14,3	13,3	11,6	9,7	7		
80-250/55	5,5	7,5	20,3											20	19,7	19,3	18,4	17,4	15,2	12,4			
80-250/75	7,5	10	22,6											22,6	22,3	22	21,3	20,3	18,5	16,1	12,2		
80-250/92	9,2	12,5	26,7											26,5	26,3	26	25,2	24,2	22,3	20,2	16,8		

* DN 25 available with the same performances of DN 32



**SH 25 - SH 32 SERIES
OPERATING CHARACTERISTICS at 2900 rpm 50 Hz, 2 POLES**

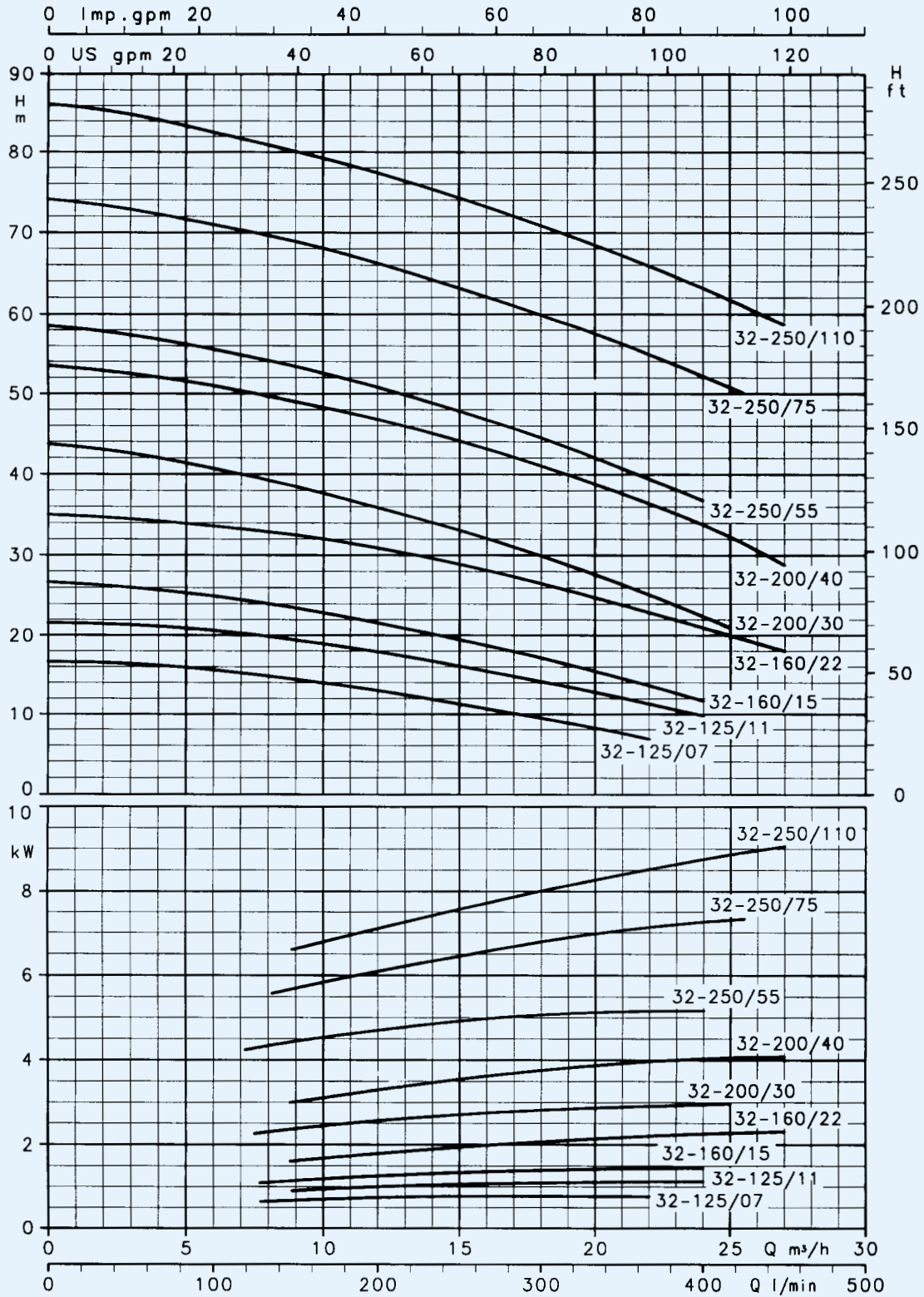

SH

Please verify with the price list the availability of model type SHE-SHS-SHF
These performances are valid for liquids with density $\rho = 1.0 \text{ kg/dm}^3$ and kinematic viscosity $\gamma = 1 \text{ mm}^2/\text{sec}$.

SH 40 SERIES OPERATING CHARACTERISTICS at 2900 rpm 50 Hz, 2 POLES

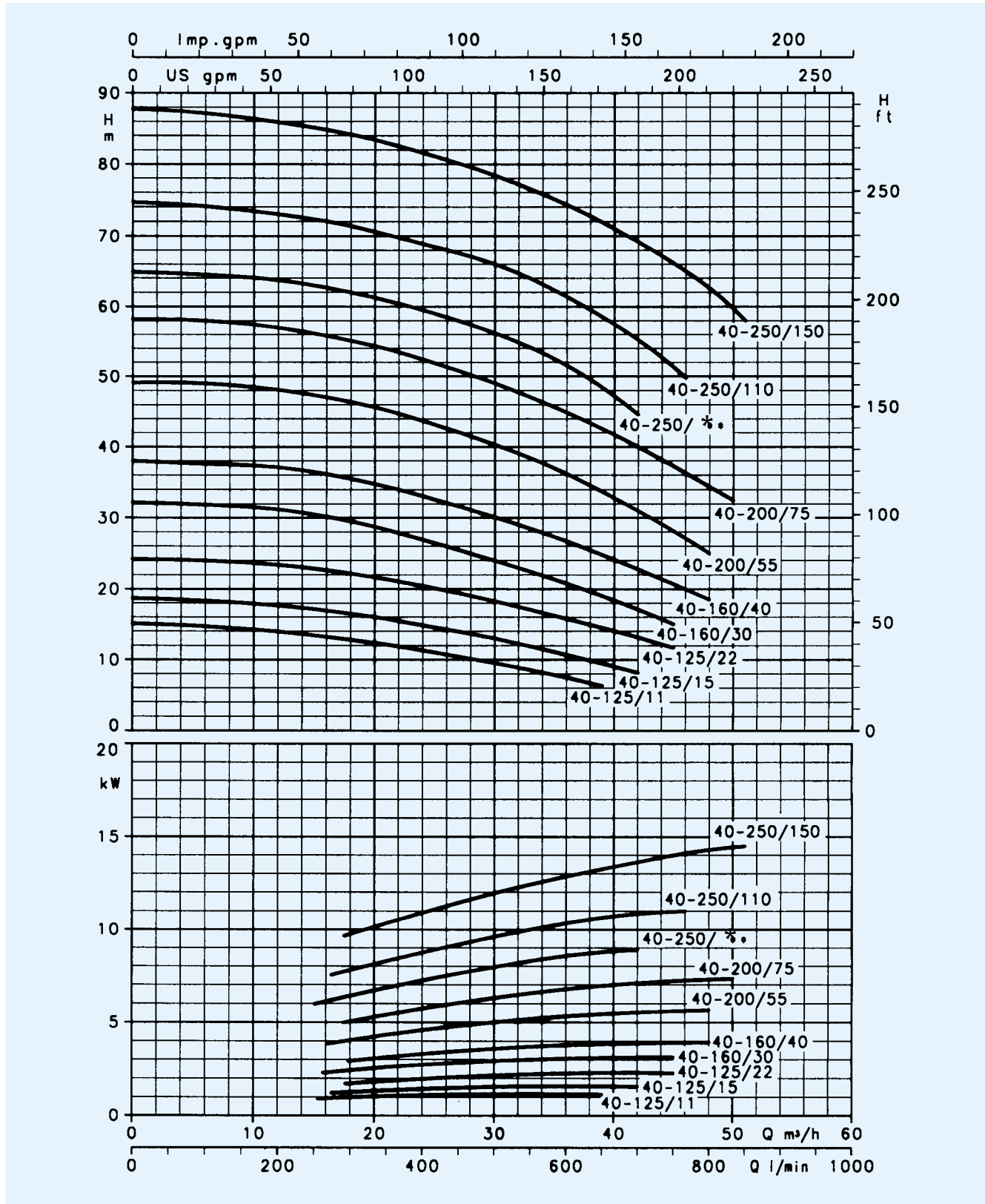

* /92 - 9,2 kW - 12,5 HP for version SHE - /110A - 11 kW - 15 HP for version SHS-SHF

Please verify with the price list the availability of model type SHE-SHS-SHF

These performances are valid for liquids with density $\rho = 1.0 \text{ kg/dm}^3$ and kinematic viscosity $\gamma = 1 \text{ mm}^2/\text{sec}$.

SH

SH 50 SERIES OPERATING CHARACTERISTICS at 2900 rpm 50 Hz, 2 POLES

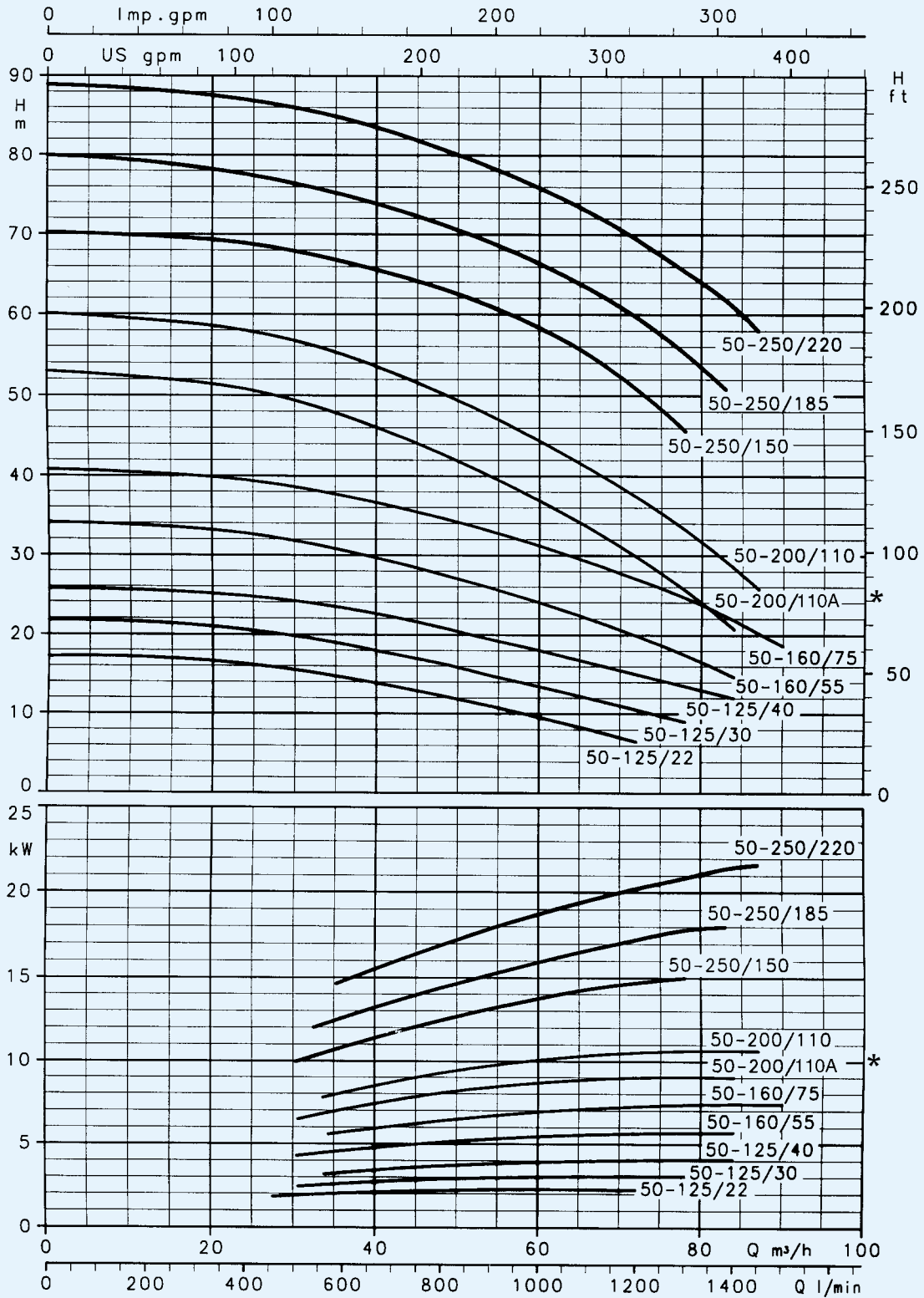

* /92 - 9,2 kW - 12,5 HP for version SHE - /110A - 11 kW - 15 HP for version SHS-SHF

Please verify with the price list the availability of model type SHE-SHS-SHF

These performances are valid for liquids with density $\rho = 1.0 \text{ kg/dm}^3$ and kinematic viscosity $\gamma = 1 \text{ mm}^2/\text{sec}$.

SH 65 SERIES OPERATING CHARACTERISTICS at 2900 rpm 50 Hz, 2 POLES

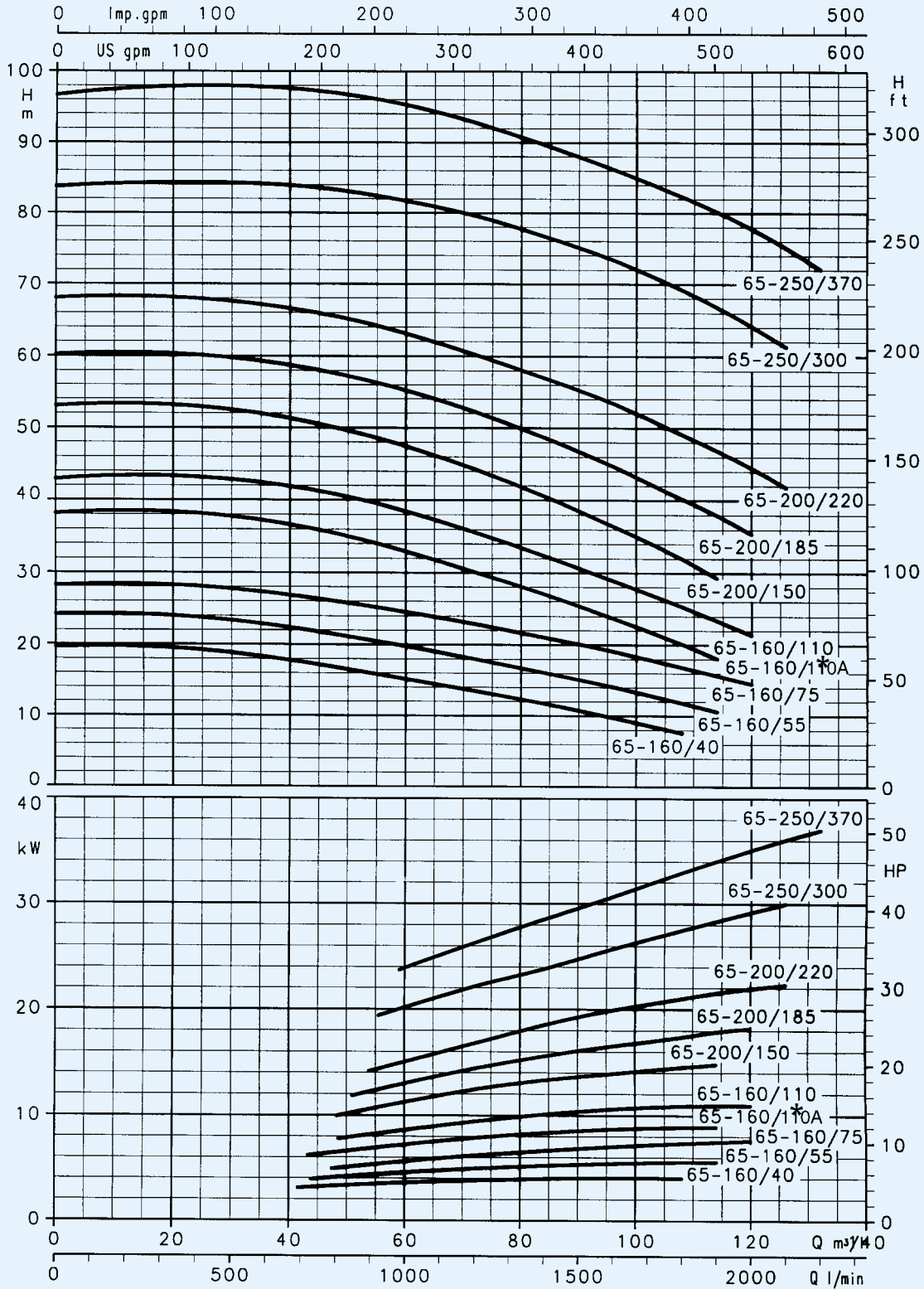

* /92 - 9,2 kW - 12,5 HP for version SHE - /110A - 11 kW - 15 HP for version SHS-SHF

Please verify with the price list the availability of model type SHE-SHS-SHF

These performances are valid for liquids with density $\rho = 1.0 \text{ kg/dm}^3$ and kinematic viscosity $\gamma = 1 \text{ mm}^2/\text{sec}$.

SH

SH 80 SERIES OPERATING CHARACTERISTICS at 2900 rpm 50 Hz, 2 POLES

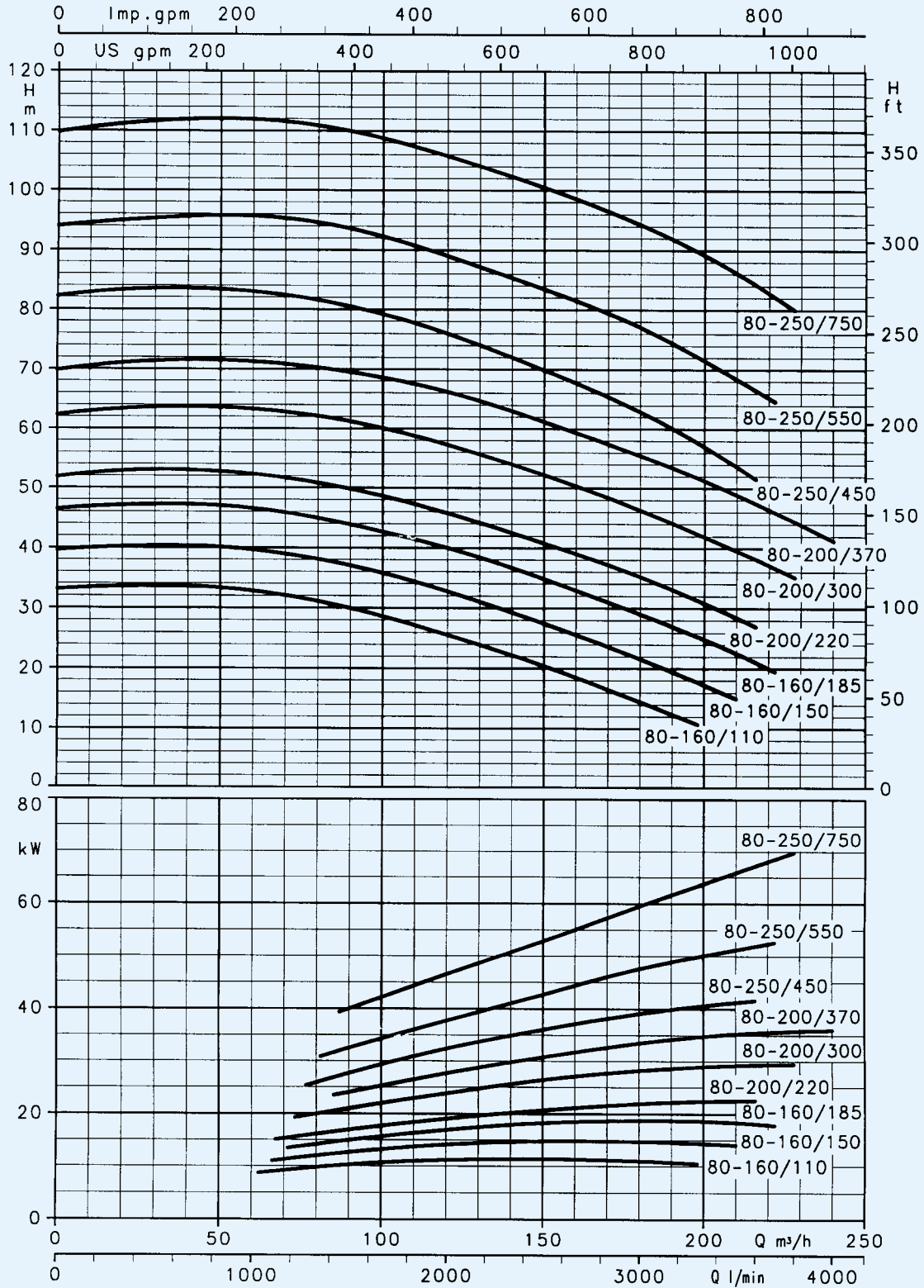

SH

Please verify with the price list the availability of model type SHE-SHS-SHF
These performances are valid for liquids with density $\rho = 1.0 \text{ kg/dm}^3$ and kinematic viscosity $\gamma = 1 \text{ mm}^2/\text{sec}$.

SH4 25 - SH4 32 SERIES
OPERATING CHARACTERISTICS at 1450 rpm 50 Hz, 4 POLES

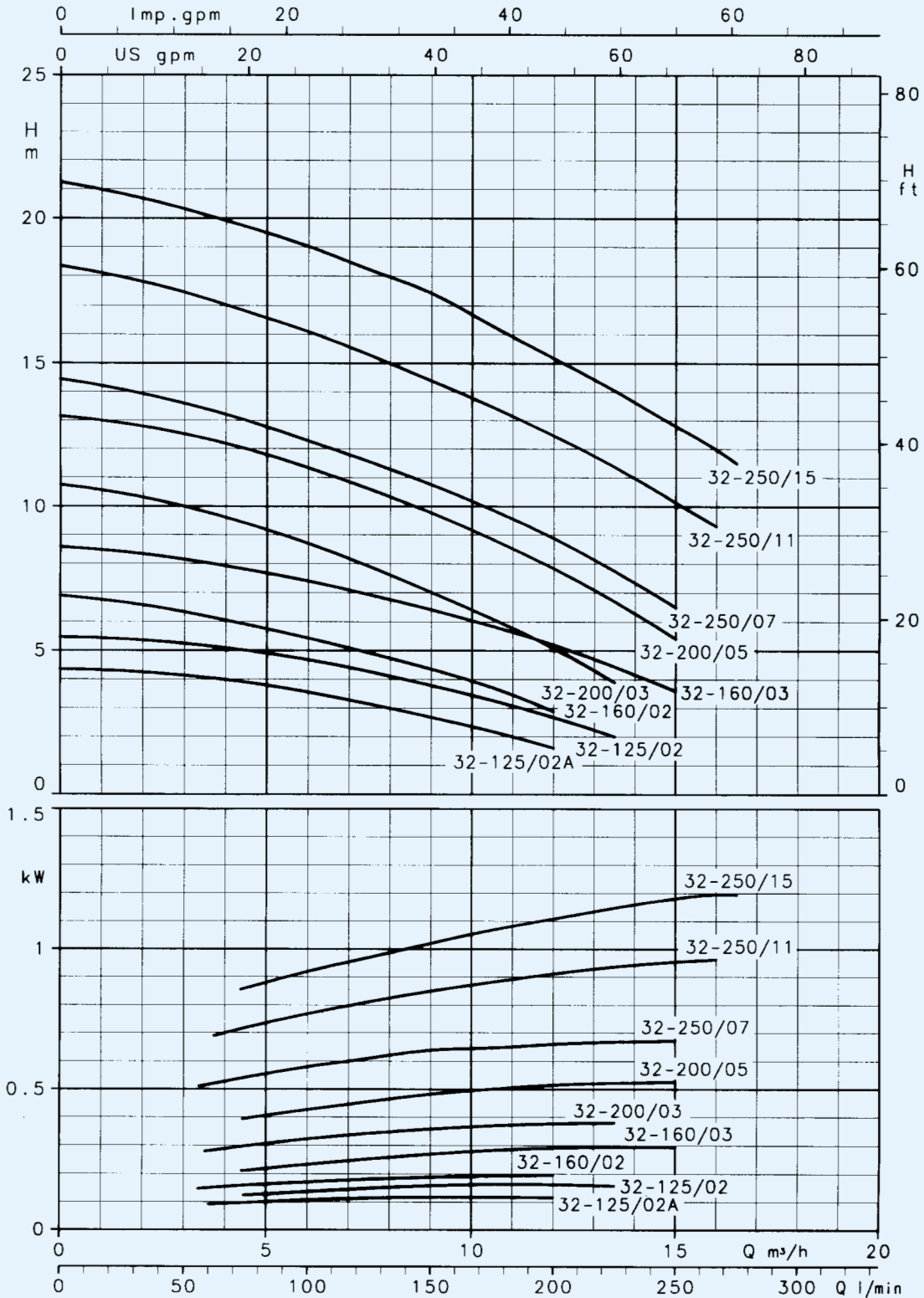

Please verify with the price list the availability of model type SHE4-SHS4-SHF4
 These performances are valid for liquids with density $\rho = 1.0 \text{ kg/dm}^3$ and kinematic viscosity $\gamma = 1 \text{ mm}^2/\text{sec}$.

SH

SH4 40 SERIES OPERATING CHARACTERISTICS at 1450 rpm 50 Hz, 4 POLES

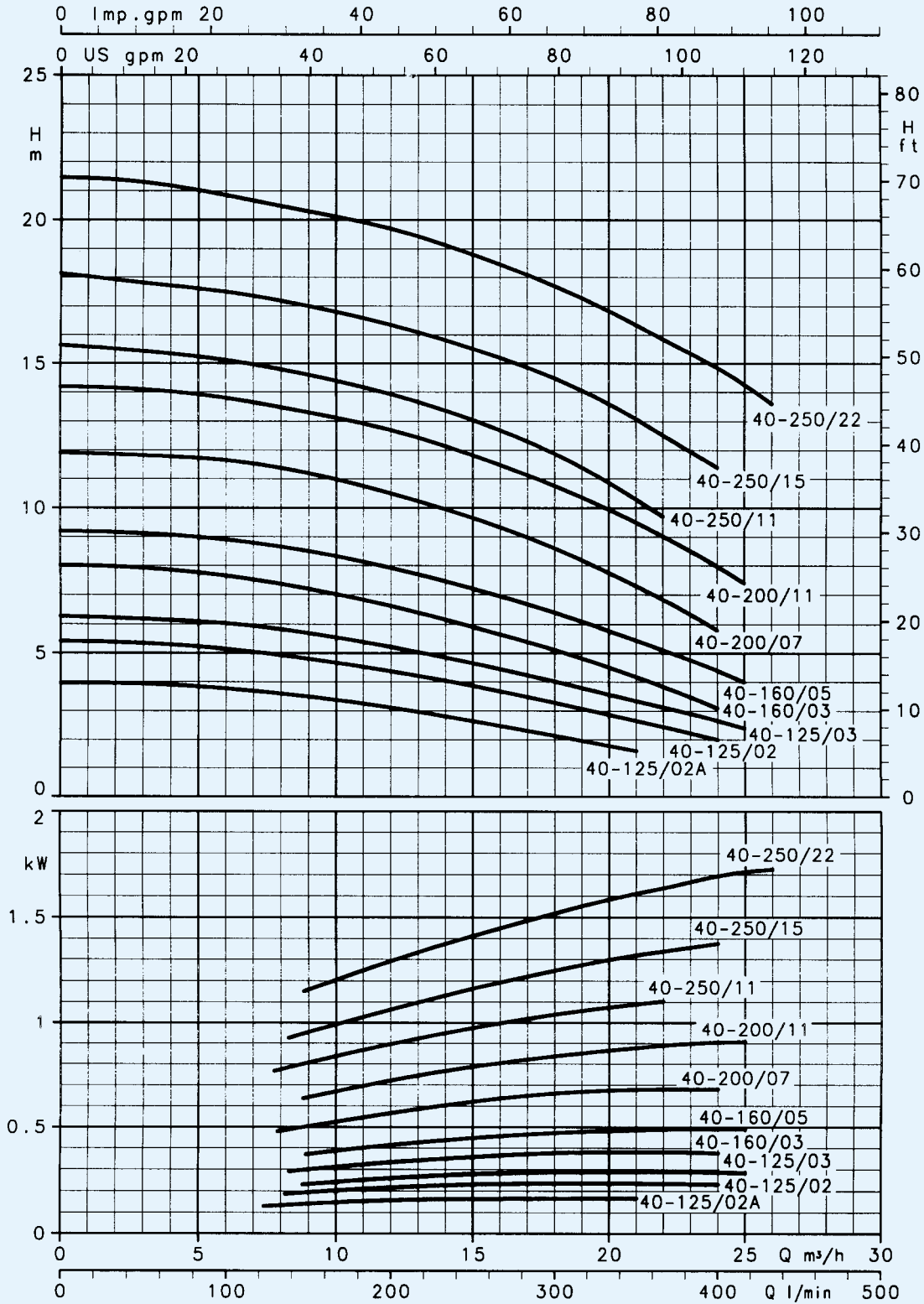

Please verify with the price list the availability of model type SHE4-SHS4-SHF4
 These performances are valid for liquids with density $\rho = 1.0 \text{ kg/dm}^3$ and kinematic viscosity $\gamma = 1 \text{ mm}^2/\text{sec}$.

SH

SH4 50 SERIES OPERATING CHARACTERISTICS at 1450 rpm 50 Hz, 4 POLES

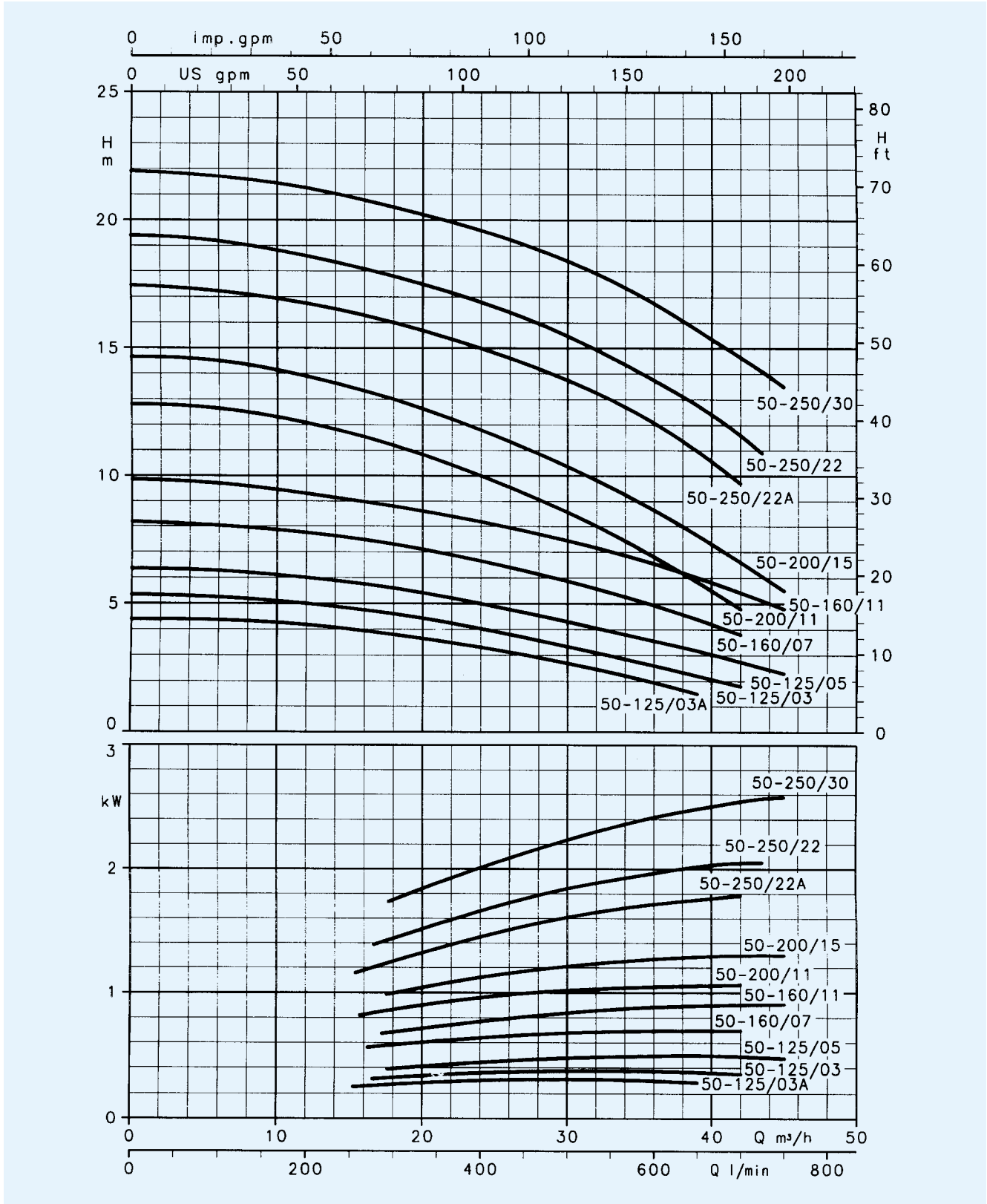

Please verify with the price list the availability of model type SHE4-SHS4-SHF4
 These performances are valid for liquids with density $\rho = 1.0 \text{ kg/dm}^3$ and kinematic viscosity $\gamma = 1 \text{ mm}^2/\text{sec}$.

SH

SH4 65 SERIES OPERATING CHARACTERISTICS at 1450 rpm 50 Hz, 4 POLES

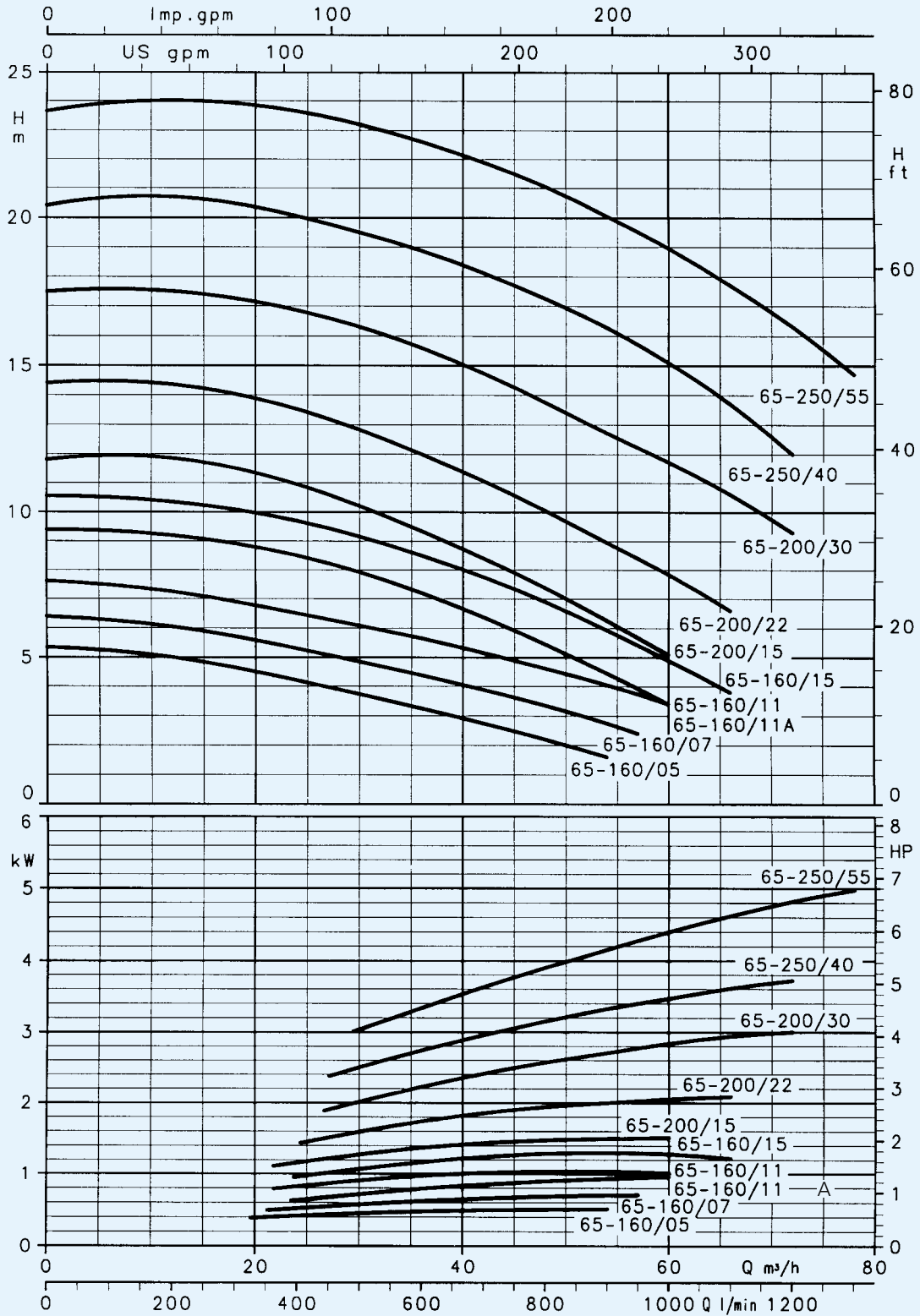

Please verify with the price list the availability of model type SHE4-SHS4-SHF4
 These performances are valid for liquids with density $\rho = 1.0 \text{ kg/dm}^3$ and kinematic viscosity $\gamma = 1 \text{ mm}^2/\text{sec}$.

SH

SH4 80 SERIES OPERATING CHARACTERISTICS at 1450 rpm 50 Hz, 4 POLES

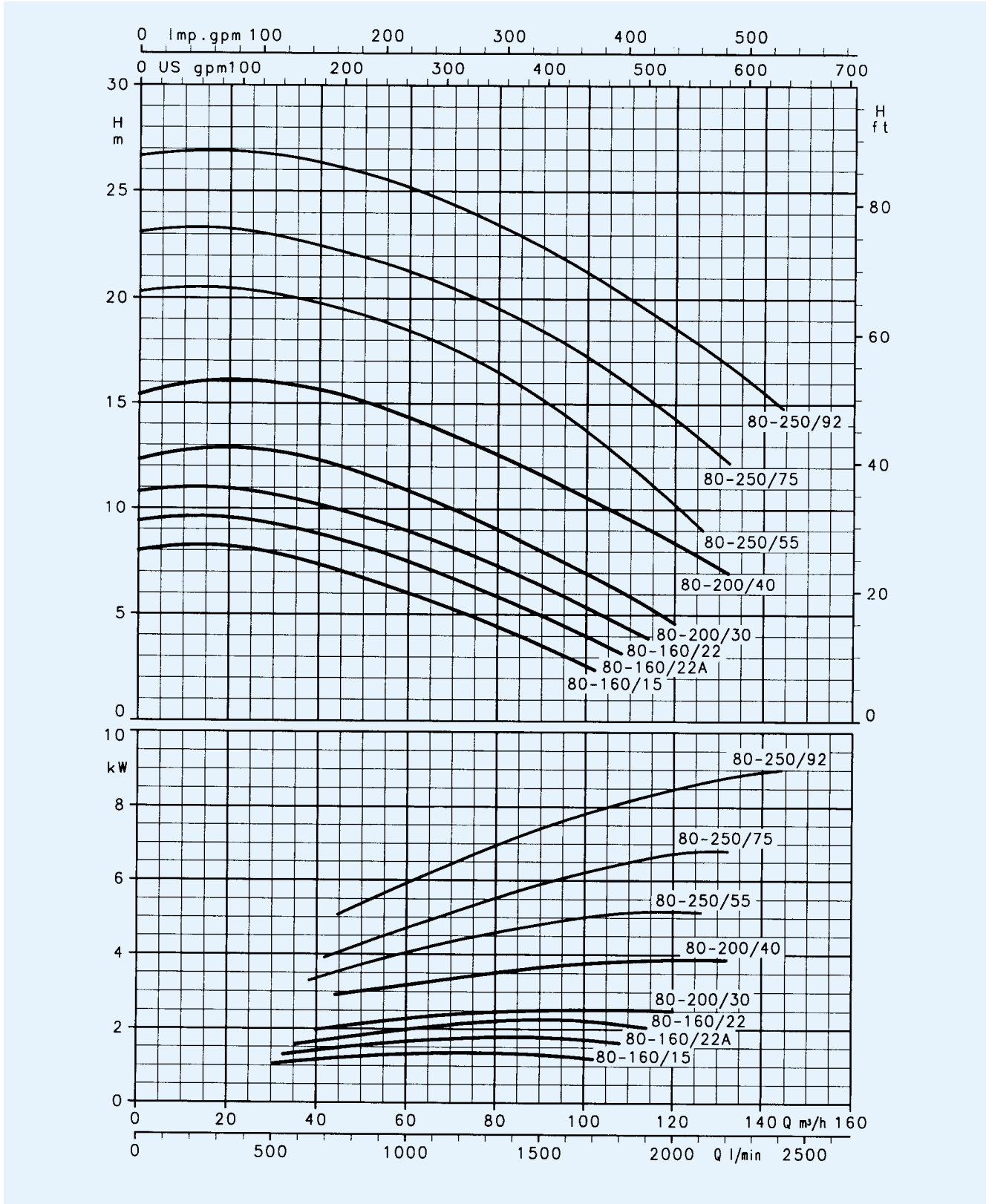

Please verify with the price list the availability of model type SHE4-SHS4-SHF4
 These performances are valid for liquids with density $\rho = 1.0 \text{ kg/dm}^3$ and kinematic viscosity $\gamma = 1 \text{ mm}^2/\text{sec}$.

SH

DIMENSIONS AND WEIGHTS SHE SERIES, 2 POLES

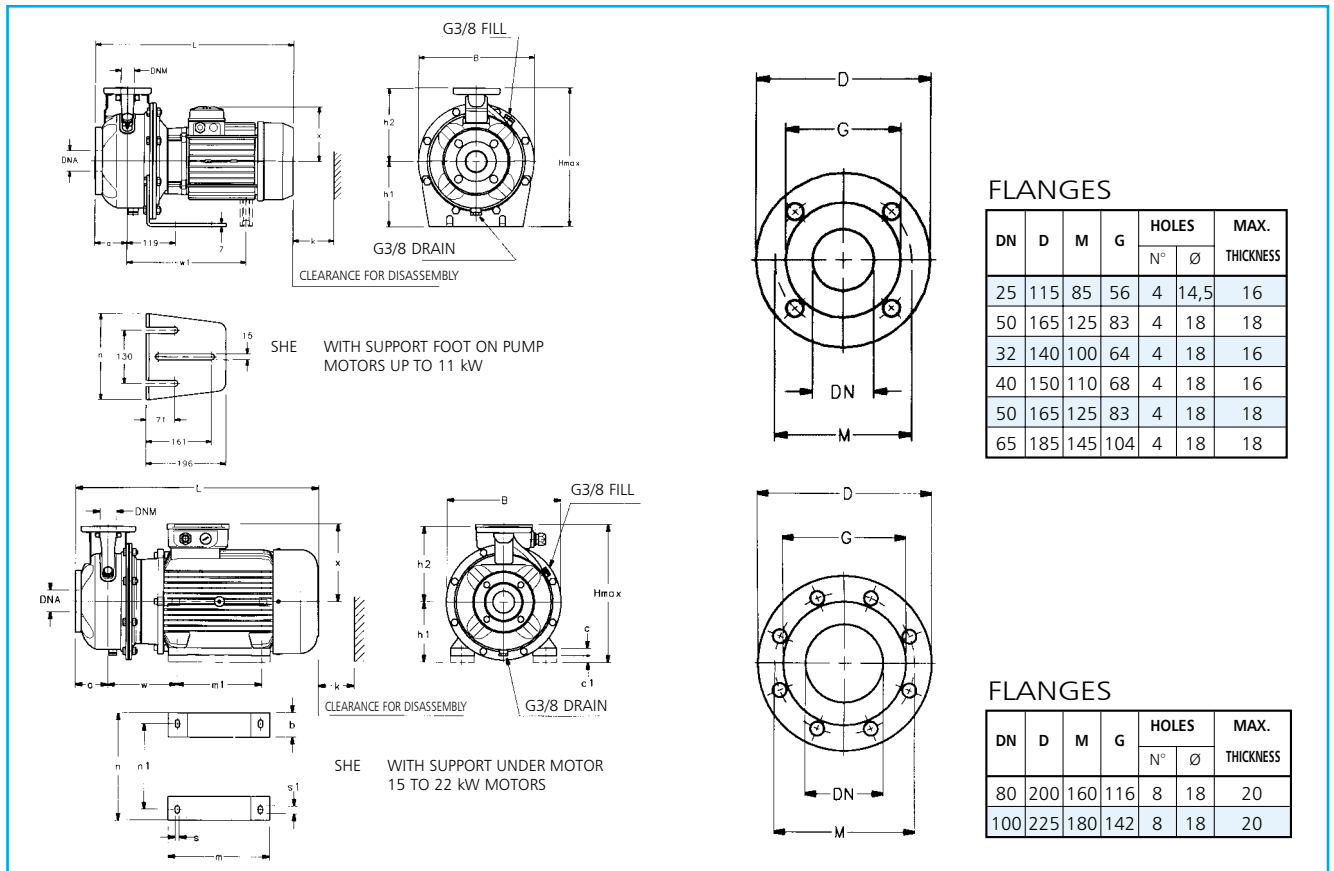

DIMENSIONS AND WEIGHTS SHE SERIES, 2 POLES

PUMP TYPE	PUMP							SUPPORT									B	H max	L	k	WEIGHT kg	
	DNM	DNA	a	h2	w	w1	x	b	c	c1	h1	m	m1	n	n1	s						s1
SHE 25-125/07	25	50	80	140	-	-	129	-	-	-	160	-	-	190	-	-	-	218	252	443	98	20
SHE 25-125/11	25	50	80	140	-	-	129	-	-	-	160	-	-	190	-	-	-	218	252	443	98	22
SHE 25-160/15	25	50	80	160	-	-	129	-	-	-	160	-	-	210	-	-	-	253	320	443	98	23
SHE 25-160/22	25	50	80	160	-	-	129	-	-	-	160	-	-	210	-	-	-	253	320	443	98	25
SHE 25-200/30	25	50	80	180	-	-	121	-	-	-	160	-	-	230	-	-	-	285	340	461	98	29
SHE 25-200/40	25	50	80	180	-	-	133	-	-	-	160	-	-	230	-	-	-	285	340	487	98	36
SHE 25-250/55	25	50	100	225	-	-	150	-	-	-	180	-	-	265	-	-	-	345	405	553	98	48
SHE 25-250/75	25	50	100	225	-	-	150	-	-	-	180	-	-	265	-	-	-	245	405	553	98	60
SHE 25-250/110	25	50	100	225	-	278	191	-	-	-	180	-	-	265	-	-	-	245	405	604	98	80
SHE 32-125/07	32	50	80	140	-	-	129	-	-	-	112	-	-	190	-	-	-	218	252	443	96	20
SHE 32-125/11	32	50	80	140	-	-	129	-	-	-	112	-	-	190	-	-	-	218	252	443	96	22
SHE 32-160/15	32	50	80	160	-	-	129	-	-	-	132	-	-	210	-	-	-	253	292	443	96	23
SHE 32-160/22	32	50	80	160	-	-	129	-	-	-	132	-	-	210	-	-	-	253	292	443	96	25
SHE 32-200/30	32	50	80	180	-	-	121	-	-	-	160	-	-	230	-	-	-	285	340	461	96	29
SHE 32-200/40	32	50	80	180	-	-	133	-	-	-	160	-	-	230	-	-	-	285	340	487	96	36
SHE 32-250/55	32	50	100	225	-	-	150	-	-	-	180	-	-	265	-	-	-	345	405	553	96	48
SHE 32-250/75	32	50	100	225	-	-	150	-	-	-	180	-	-	265	-	-	-	345	405	553	96	60
SHE 32-250/110	32	50	100	225	-	278	191	-	-	-	180	-	-	265	-	-	-	345	405	604	96	80
SHE 40-125/11	40	65	80	140	-	-	129	-	-	-	112	-	-	190	-	-	-	219	252	443	100	23
SHE 40-125/15	40	65	80	140	-	-	129	-	-	-	112	-	-	190	-	-	-	219	252	443	100	25
SHE 40-125/22	40	65	80	140	-	-	129	-	-	-	112	-	-	190	-	-	-	219	252	443	100	26
SHE 40-160/30	40	65	80	160	-	-	121	-	-	-	132	-	-	210	-	-	-	254	292	461	100	29
SHE 40-160/40	40	65	80	160	-	-	133	-	-	-	132	-	-	210	-	-	-	254	292	487	100	35
SHE 40-200/55	40	65	100	180	-	-	150	-	-	-	160	-	-	230	-	-	-	285	340	553	100	46
SHE 40-200/75	40	65	100	180	-	-	150	-	-	-	160	-	-	230	-	-	-	285	340	553	100	51
SHE 40-250/92	40	65	100	225	-	278	191	-	-	-	180	-	-	265	-	-	-	345	405	604	107	62
SHE 40-250/110	40	65	100	225	-	278	191	-	-	-	180	-	-	265	-	-	-	345	405	604	107	65
SHE 40-250/150	40	65	100	225	208	-	232	72	22	20	180	260	210	318	254	13	23	345	412	688	107	91
SHE 50-125/22	50	65	100	160	-	-	129	-	-	-	132	-	-	210	-	-	-	254	292	463	104	29
SHE 50-125/30	50	65	100	160	-	-	121	-	-	-	132	-	-	210	-	-	-	254	292	481	104	32
SHE 50-125/40	50	65	100	160	-	-	135	-	-	-	132	-	-	210	-	-	-	254	292	507	104	35
SHE 50-160/55	50	65	100	180	-	-	150	-	-	-	160	-	-	210	-	-	-	255	340	553	104	47
SHE 50-160/75	50	65	100	180	-	-	150	-	-	-	160	-	-	210	-	-	-	255	340	553	104	52
SHE 50-200/92	50	65	100	200	-	278	191	-	-	-	160	-	-	245	-	-	-	310	360	604	104	63
SHE 50-200/110	50	65	100	200	-	278	191	-	-	-	160	-	-	245	-	-	-	310	360	604	104	67
SHE 50-250/150	50	65	100	225	208	-	232	72	22	20	180	260	210	318	254	13	23	345	412	688	107	103
SHE 50-250/185	50	65	100	225	208	-	232	72	22	20	180	304	254	318	254	13	23	345	412	732	107	119
SHE 50-250/220	50	65	100	225	208	-	232	72	22	20	180	304	254	318	254	13	23	345	412	732	107	136
SHE 65-160/40	65	80	100	200	-	-	133	-	-	-	160	-	-	245	-	-	-	310	360	507	115	60
SHE 65-160/55	65	80	100	200	-	-	150	-	-	-	160	-	-	245	-	-	-	310	360	553	115	69
SHE 65-160/75	65	80	100	200	-	-	150	-	-	-	160	-	-	245	-	-	-	310	360	553	115	75
SHE 65-160/92	65	80	100	200	-	278	191	-	-	-	160	-	-	245	-	-	-	310	360	604	130	92
SHE 65-160/110	65	80	100	200	-	278	191	-	-	-	160	-	-	245	-	-	-	310	360	604	130	101
SHE 65-200/150	65	80	100	225	208	-	232	72	22	20	180	260	210	318	254	13	23	310	412	688	130	116
SHE 65-200/185	65	80	100	225	208	-	232	72	22	20	180	304	254	318	254	13	23	310	412	732	130	126
SHE 65-200/220	65	80	100	225	208	-	232	72	22	20	180	304	254	318	254	13	23	310	412	732	130	139
SHE 80-160/110	80	100	125	235	-	278	191	-	-	-	180	-	-	265	-	-	-	345	405	629	160	102
SHE 80-160/150	80	100	125	235	208	-	232	72	22	20	180	260	210	318	254	13	23	345	412	713	160	120
SHE 80-160/185	80	100	125	235	208	-	232	72	22	20	180	304	254	318	254	13	23	345	412	757	160	139
SHE 80-200/220	80	100	125	250	208	-	232	72	22	20	180	304	254	318	254	13	23	345	430	757	160	150

HS

DIMENSIONS AND WEIGHTS SHE4 SERIES, 4 POLES

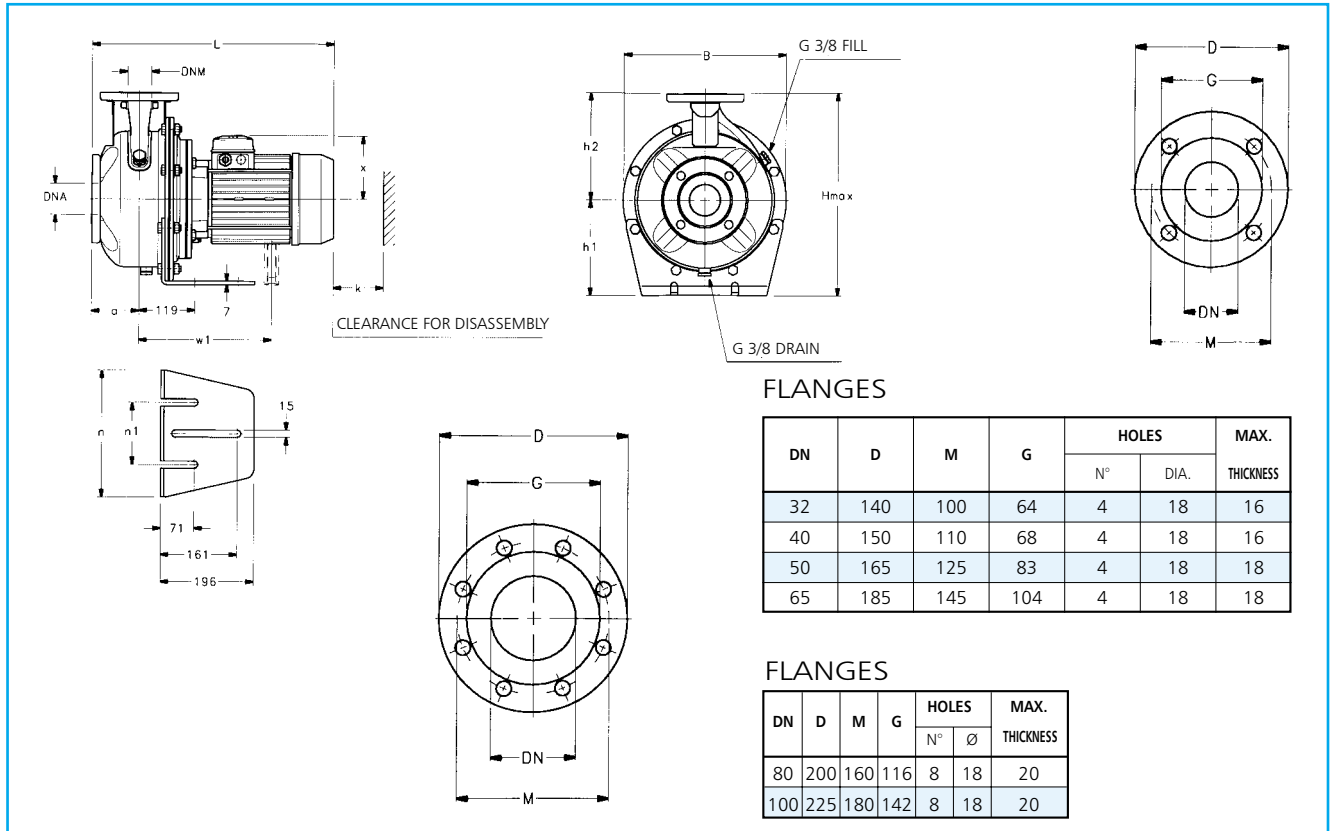

DIMENSIONS AND WEIGHTS SHE4 SERIES, 4 POLES

PUMP TYPE	PUMP						DIMENSIONS IN mm			B	H max	L	k	WEIGHT kg
	DNM	DNA	a	h2	w1	x	h1	n	n1					
SHE4 25-125/02A	25	50	80	140	-	121	160	190	130	218	252	411	98	20
SHE4 25-125/02	25	50	80	140	-	121	160	190	130	218	252	411	98	20
SHE4 25-160/02	25	50	80	160	-	121	160	210	130	253	320	411	98	22
SHE4 25-160/03	25	50	80	160	-	121	160	210	130	253	320	411	98	23
SHE4 25-200/03	25	50	80	180	-	121	160	230	130	285	340	411	98	28
SHE4 25-200/05	25	50	80	180	-	129	160	230	130	285	340	443	98	30
SHE4 25-250/07	25	50	100	225	-	129	180	265	130	345	405	463	98	38
SHE4 25-250/11	25	50	100	225	-	121	180	265	130	345	405	481	98	40
SHE4 25-250/15	25	50	100	225	-	121	180	265	130	345	405	481	98	45
SHE4 32-125/02A	32	50	80	140	-	121	112	190	130	218	252	411	98	20
SHE4 32-125/02	32	50	80	140	-	121	112	190	130	218	252	411	98	20
SHE4 32-160/02	32	50	80	160	-	121	132	210	130	253	292	411	98	22
SHE4 32-160/03	32	50	80	160	-	121	132	210	130	253	292	411	98	23
SHE4 32-200/03	32	50	80	180	-	121	160	230	130	285	340	411	98	28
SHE4 32-200/05	32	50	80	180	-	129	160	230	130	285	340	443	98	30
SHE4 32-250/07	32	50	100	225	-	129	180	265	130	345	405	463	98	38
SHE4 32-250/11	32	50	100	225	-	121	180	265	130	345	405	481	98	40
SHE4 32-250/15	32	50	100	225	-	121	180	265	130	345	405	481	98	45
SHE4 40-125/02A	40	65	80	140	-	121	112	190	130	219	252	411	100	21
SHE4 40-125/02	40	65	80	140	-	121	112	190	130	219	252	411	100	21
SHE4 40-125/03	40	65	80	140	-	121	112	190	130	219	252	411	100	22
SHE4 40-160/03	40	65	80	160	-	121	132	210	130	254	292	411	100	24
SHE4 40-160/05	40	65	80	160	-	129	132	210	130	254	292	411	100	25
SHE4 40-200/07	40	65	100	180	-	129	160	230	130	285	340	443	100	26
SHE4 40-200/11	40	65	100	180	-	121	160	230	130	285	340	463	100	30
SHE4 40-250/11	40	65	100	225	-	121	180	265	130	345	405	481	107	32
SHE4 40-250/15	40	65	100	225	-	121	180	265	130	345	405	481	107	42
SHE4 40-250/22	40	65	100	225	-	133	180	265	130	345	405	507	107	49
SHE4 50-125/03A	50	65	100	160	-	121	132	210	130	254	292	431	104	22
SHE4 50-125/03	50	65	100	160	-	121	132	210	130	254	292	431	104	22
SHE4 50-125/05	50	65	100	160	-	129	132	210	130	254	292	463	104	24
SHE4 50-160/07	50	65	100	180	-	129	160	210	130	255	340	463	104	26
SHE4 50-160/11	50	65	100	180	-	121	160	210	130	255	340	481	104	28
SHE4 50-200/11	50	65	100	200	-	121	160	245	130	310	360	481	104	30
SHE4 50-200/15	50	65	100	200	-	121	160	245	130	310	360	481	104	41
SHE4 50-250/22A	50	65	100	225	-	133	180	265	130	345	405	507	107	46
SHE4 50-250/22	50	65	100	225	-	133	180	265	130	345	405	507	107	46
SHE4 50-250/30	50	65	100	225	-	133	180	265	130	345	405	507	107	55
SHE4 65-160/05	65	80	100	200	-	129	160	245	130	310	360	463	115	32
SHE4 65-160/07	65	80	100	200	-	129	160	245	130	310	360	463	115	35
SHE4 65-160/11A	65	80	100	200	-	121	160	245	130	310	360	481	115	38
SHE4 65-160/11	65	80	100	200	-	121	160	245	130	310	360	481	130	38
SHE4 65-160/15	65	80	100	200	-	121	160	245	130	310	360	481	130	42
SHE4 65-200/15	65	80	100	225	-	121	180	245	130	310	405	481	130	45
SHE4 65-200/22	65	80	100	225	-	133	180	245	130	310	405	507	130	50
SHE4 65-200/30	65	80	100	225	-	133	180	245	130	310	405	507	130	55
SHE4 65-250/40	65	80	100	250	-	150	200	265	130	345	450	530	140	64
SHE4 65-250/55	65	80	100	250	-	191	200	265	130	345	450	566	140	78
SHE4 80-160/15	80	100	125	225	-	121	180	265	130	345	405	506	160	49
SHE4 80-160/22A	80	100	125	225	-	133	180	265	130	345	405	532	160	54
SHE4 80-160/22	80	100	125	225	-	133	180	265	130	345	405	532	160	54
SHE4 80-200/30	80	100	125	250	-	133	180	265	130	345	430	532	160	59
SHE4 80-200/40	80	100	125	250	-	150	180	265	130	345	430	555	160	65
SHE4 80-250/55	80	100	125	280	259	191	200	303	210	384	480	591	160	79
SHE4 80-250/75	80	100	125	280	278	191	200	303	210	384	480	629	160	87
SHE4 80-250/92	80	100	125	280	278	191	200	303	210	384	480	629	160	88

HS

DIMENSIONS AND WEIGHTS SHS SERIES, 2 POLES

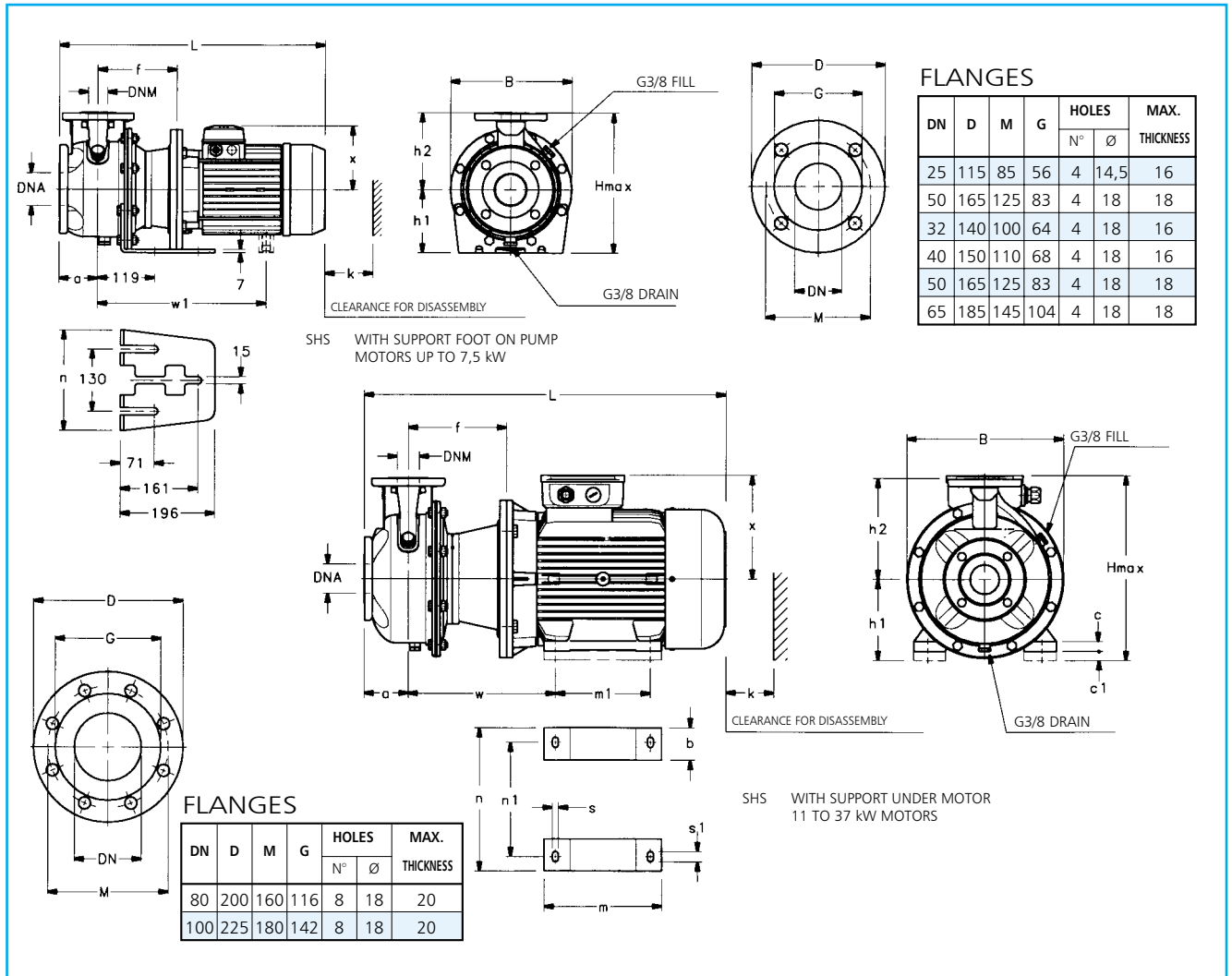

DIMENSIONS AND WEIGHTS SHS4 SERIES, 4 POLES

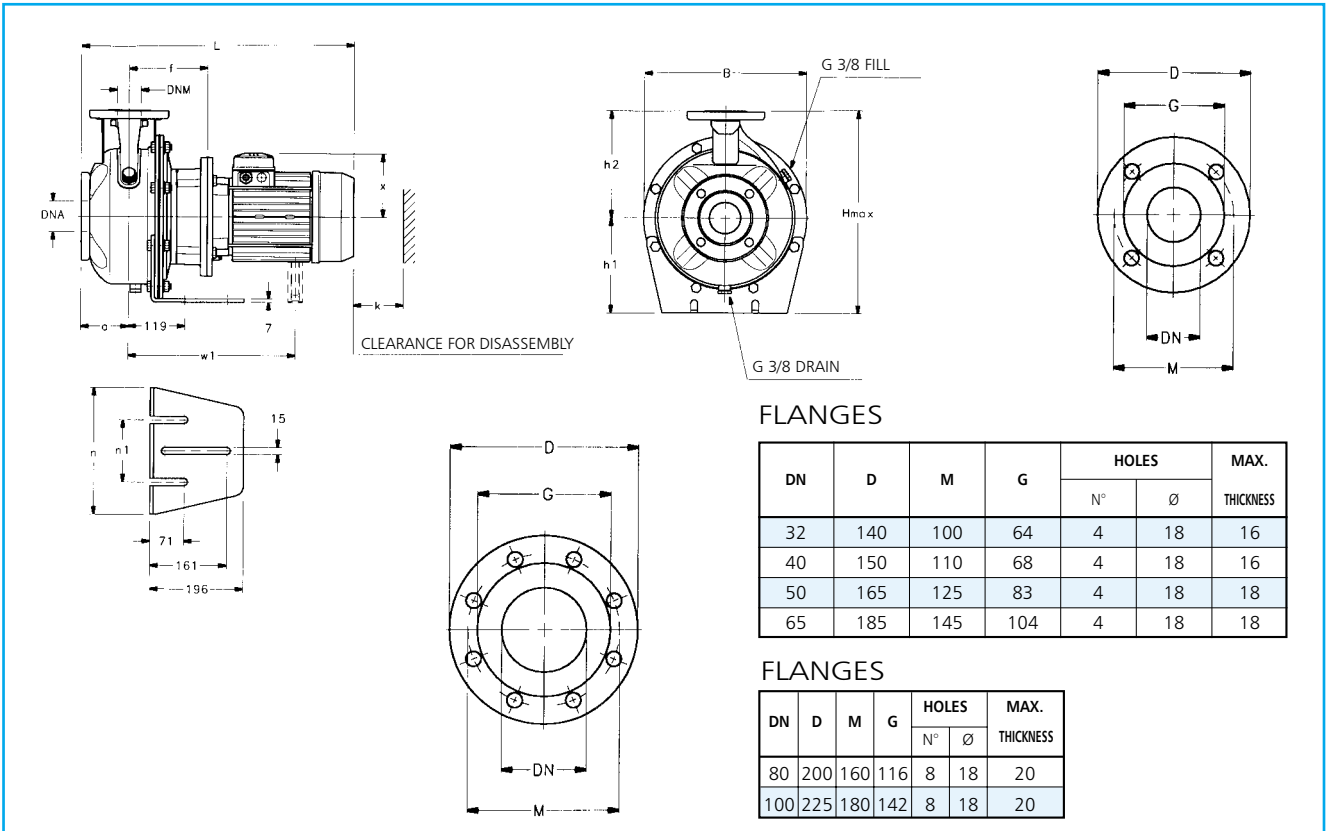

SH

DIMENSIONS AND WEIGHTS SHS4 SERIES, 4 POLES

PUMP TYPE	PUMP							DIMENSIONS IN mm			B	H max	L	k	WEIGHT kg
	DNM	DNA	a	f	h2	w1	x	h1	n	n1					
SHS4 25-250/07	25	50	100	155	225	–	129	180	265	–	345	405	518	98	41
SHS4 25-250/11	25	50	100	155	225	–	121	180	265	–	345	405	536	98	43
SHS4 25-250/15	25	50	100	155	225	–	121	180	265	–	345	405	536	98	47
SHS4 32-250/07	32	50	100	155	225	–	129	180	265	130	345	405	518	98	41
SHS4 32-250/11	32	50	100	155	225	–	121	180	265	130	345	405	536	98	43
SHS4 32-250/15	32	50	100	155	225	–	121	180	265	130	345	405	536	98	47
SHS4 40-200/07	40	65	100	155	180	–	129	160	230	130	285	340	518	100	28
SHS4 40-200/11	40	65	100	155	180	–	121	160	230	130	285	340	536	100	32
SHS4 40-250/11	40	65	100	155	225	–	121	180	265	130	345	405	536	107	33
SHS4 40-250/15	40	65	100	155	225	–	121	180	265	130	345	405	536	107	46
SHS4 40-250/22	40	65	100	165	225	–	133	180	265	130	345	405	572	107	52
SHS4 50-160/07	50	65	100	155	180	–	129	160	210	130	255	340	518	104	27
SHS4 50-160/11	50	65	100	155	180	–	121	160	210	130	255	340	536	104	30
SHS4 50-200/11	50	65	100	155	200	–	121	160	245	130	310	360	536	104	34
SHS4 50-200/15	50	65	100	155	200	–	121	160	245	130	310	360	536	104	42
SHS4 50-250/22A	50	65	100	165	225	–	133	180	265	130	345	405	572	107	49
SHS4 50-250/22	50	65	100	165	225	–	133	180	265	130	345	405	572	107	49
SHS4 50-250/30	50	65	100	165	225	–	133	180	265	130	345	405	572	107	58
SHS4 65-160/05	65	80	100	155	200	–	129	160	245	130	310	360	518	115	34
SHS4 65-160/07	65	80	100	155	200	–	129	160	245	130	310	360	518	115	37
SHS4 65-160/11A	65	80	100	155	200	–	121	160	245	130	310	360	536	115	40
SHS4 65-160/11	65	80	100	155	200	–	121	160	245	130	310	360	536	130	40
SHS4 65-160/15	65	80	100	155	200	–	121	160	245	130	310	360	536	130	45
SHS4 65-200/15	65	80	100	155	225	–	121	180	245	130	310	405	536	130	48
SHS4 65-200/22	65	80	100	165	225	–	133	180	245	130	310	405	572	130	54
SHS4 65-200/30	65	80	100	165	225	–	133	180	245	130	310	405	572	130	59
SHS4 65-250/40	65	80	100	165	250	–	150	200	265	130	345	450	595	140	65
SHS4 65-250/55	65	80	100	192	250	351	191	200	265	130	345	450	658	140	79
SHS4 80-160/15	80	100	125	155	225	–	121	180	265	130	345	405	561	160	53
SHS4 80-160/22A	80	100	125	165	225	–	133	180	265	130	345	405	597	160	58
SHS4 80-160/22	80	100	125	165	225	–	133	180	265	130	345	405	597	160	58
SHS4 80-200/30	80	100	125	165	250	–	133	180	265	130	345	430	597	160	63
SHS4 80-200/40	80	100	125	165	250	–	150	180	265	130	345	430	620	160	68
SHS4 80-250/55	80	100	125	192	280	351	191	200	303	210	384	480	683	160	85
SHS4 80-250/75	80	100	125	192	280	370	191	200	303	210	384	480	721	160	90
SHS4 80-250/92	80	100	125	192	280	370	191	200	303	210	384	480	721	160	91

DIMENSIONS AND WEIGHTS SHF SERIES, 2 POLES

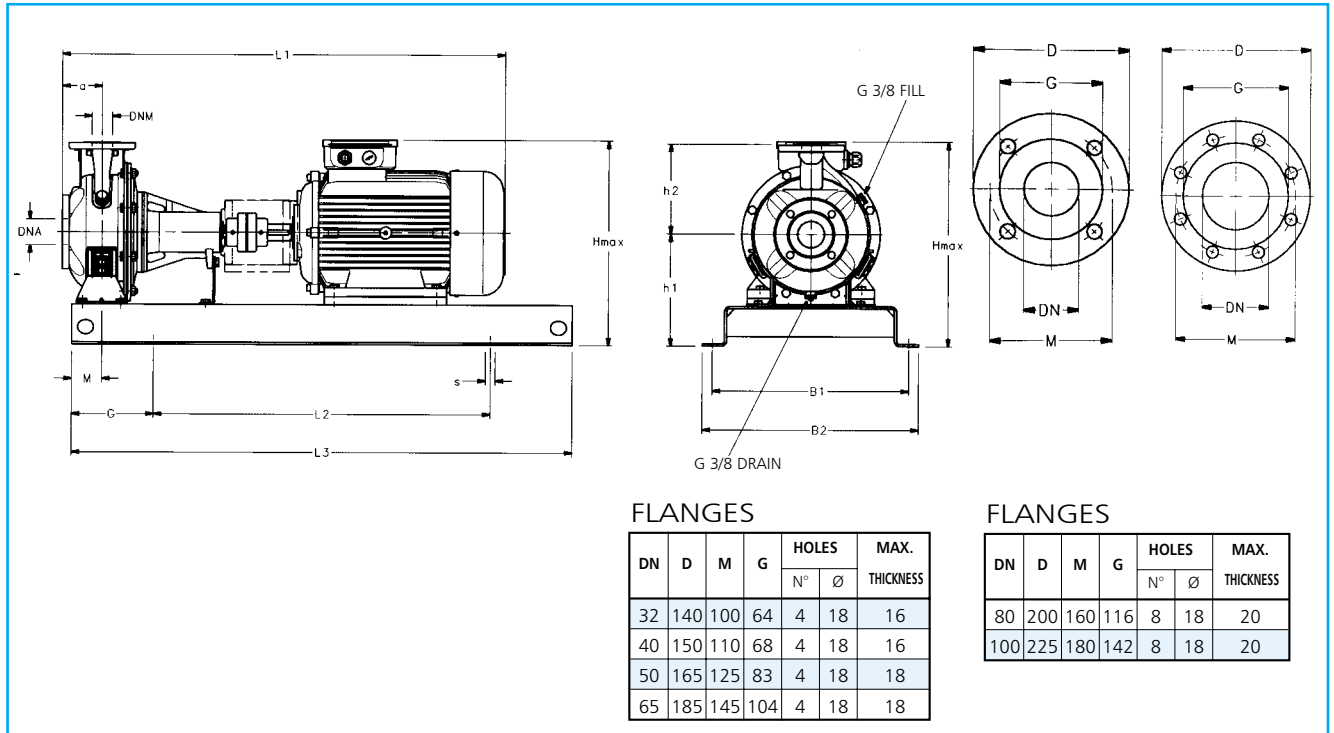

FLANGES

DN	D	M	G	HOLES		MAX. THICKNESS
				N°	Ø	
32	140	100	64	4	18	16
40	150	110	68	4	18	16
50	165	125	83	4	18	18
65	185	145	104	4	18	18

FLANGES

DN	D	M	G	HOLES		MAX. THICKNESS
				N°	Ø	
80	200	160	116	8	18	20
100	225	180	142	8	18	20

SH

DIMENSIONS AND WEIGHTS SHF SERIES, 2 POLES

PUMP TYPE	DIMENSIONS (mm)													s for screws	WEIGHT kg
	DNM	DNA	a	B1	B2	L1	L2	L3	G	M	h1	h2	Hmax		
SHF 25-125/07	25	50	80	320	360	744	540	800	130	60	212	140	352	M16	65
SHF 25-125/11	25	50	80	320	360	744	540	800	130	60	212	140	352	M16	67
SHF 25-160/15	25	50	80	350	390	773	600	900	150	60	232	160	392	M16	69
SHF 25-160/22	25	50	80	350	390	773	600	900	150	60	232	160	392	M16	71
SHF 25-200/30	25	50	80	350	390	809	600	900	150	60	260	180	440	M16	90
SHF 25-200/40	25	50	80	350	390	832	600	900	150	60	260	180	440	M16	94
SHF 25-250/55	25	50	100	440	490	909	740	1120	190	75	280	225	505	M20	126
SHF 25-250/75	25	50	100	440	490	909	740	1120	190	75	280	225	505	M20	131
SHF 25-250/110	25	50	100	490	540	1061	840	1250	205	75	280	225	512	M20	176
SHF 32-125/07	32	50	80	320	360	744	540	800	130	60	212	140	352	M16	65
SHF 32-125/11	32	50	80	320	360	744	540	800	130	60	212	140	352	M16	67
SHF 32-160/15	32	50	80	350	390	773	600	900	150	60	232	160	392	M16	69
SHF 32-160/22	32	50	80	350	390	773	600	900	150	60	232	160	392	M16	71
SHF 32-200/30	32	50	80	350	390	809	600	900	150	60	260	180	440	M16	90
SHF 32-200/40	32	50	80	350	390	832	600	900	150	60	260	180	440	M16	94
SHF 32-250/55	32	50	100	440	490	909	740	1120	190	75	280	225	505	M20	126
SHF 32-250/75	32	50	100	440	490	909	740	1120	190	75	280	225	505	M20	131
SHF 32-250/110	32	50	100	490	540	1061	840	1250	205	75	280	225	512	M20	176
SHF 40-125/11	40	65	80	320	360	744	540	800	130	60	212	140	352	M16	68
SHF 40-125/15	40	65	80	350	390	773	600	900	150	60	212	140	352	M16	70
SHF 40-125/22	40	65	80	350	390	773	600	900	150	60	212	140	352	M16	73
SHF 40-160/30	40	65	80	350	390	809	600	900	150	60	232	160	392	M16	87
SHF 40-160/40	40	65	80	350	390	832	600	900	150	60	232	160	392	M16	93
SHF 40-200/55	40	65	100	400	450	909	660	1000	170	60	260	180	451	M20	108
SHF 40-200/75	40	65	100	400	450	909	660	1000	170	60	260	180	451	M20	116
SHF 40-250/110A	40	65	100	490	540	1061	840	1250	205	75	280	225	512	M20	174
SHF 40-250/110	40	65	100	490	540	1061	840	1250	205	75	280	225	512	M20	174
SHF 40-250/150	40	65	100	490	540	1061	840	1250	205	75	280	225	512	M20	184
SHF 50-125/22	50	65	100	350	390	793	600	900	150	60	232	160	392	M16	80
SHF 50-125/30	50	65	100	350	390	829	600	900	150	60	232	160	392	M16	87
SHF 50-125/40	50	65	100	350	390	852	600	900	150	60	232	160	392	M16	92
SHF 50-160/55	50	65	100	400	450	909	660	1000	170	60	260	180	451	M20	106
SHF 50-160/75	50	65	100	400	450	909	660	1000	170	60	260	180	451	M20	110
SHF 50-200/110A	50	65	100	440	490	1061	740	1120	190	60	260	200	492	M20	168
SHF 50-200/110	50	65	100	440	490	1061	740	1120	190	60	260	200	492	M20	168
SHF 50-250/150	50	65	100	490	540	1061	840	1250	205	75	280	225	512	M20	174
SHF 50-250/185	50	65	100	490	540	1105	840	1250	205	75	280	225	512	M20	194
SHF 50-250/220	50	65	100	490	540	1111	840	1250	205	75	280	225	510	M20	214
SHF 65-160/40	65	80	100	400	450	852	660	1000	170	75	260	200	460	M20	130
SHF 65-160/55	65	80	100	440	490	909	740	1120	190	75	260	200	460	M20	136
SHF 65-160/75	65	80	100	440	490	909	740	1120	190	75	260	200	460	M20	142
SHF 65-160/110A	65	80	100	490	540	1061	840	1250	205	75	260	200	492	M20	157
SHF 65-160/110	65	80	100	490	540	1061	840	1250	205	75	260	200	492	M20	157
SHF 65-200/150	65	80	100	490	540	1061	840	1250	205	75	280	225	512	M20	180
SHF 65-200/185	65	80	100	490	540	1105	840	1250	205	75	280	225	512	M20	192
SHF 65-200/220	65	80	100	490	540	1111	840	1250	205	75	280	225	510	M20	208
SHF 65-250/300	65	80	100	550	610	1296	940	1400	230	90	310	250	557	M24	271
SHF 65-250/370	65	80	100	550	610	1296	940	1400	230	90	310	250	557	M24	296
SHF 80-160/110	80	100	125	490	540	1086	840	1250	205	75	280	225	512	M20	193
SHF 80-160/150	80	100	125	490	540	1086	840	1250	205	75	280	225	512	M20	204
SHF 80-160/185	80	100	125	490	540	1130	840	1250	205	75	280	225	512	M20	225
SHF 80-200/220	80	100	125	490	540	1246	840	1250	205	75	280	250	530	M20	236
SHF 80-200/300	80	100	125	550	610	1321	940	1400	230	75	310	250	557	M24	277
SHF 80-200/370	80	100	125	550	610	1321	940	1400	230	75	310	250	557	M24	295
SHF 80-250/450	80	100	125	550	610	1398	940	1400	230	90	365	280	605	M24	355
SHF 80-250/550	80	100	125	600	660	1428	1060	1600	270	90	390	280	660	M24	394
SHF 80-250/750	80	100	125	670	730	1558	1200	1800	300	90	420	280	735	M24	510

SH

DIMENSIONS AND WEIGHTS SHF4 SERIES, 4 POLES

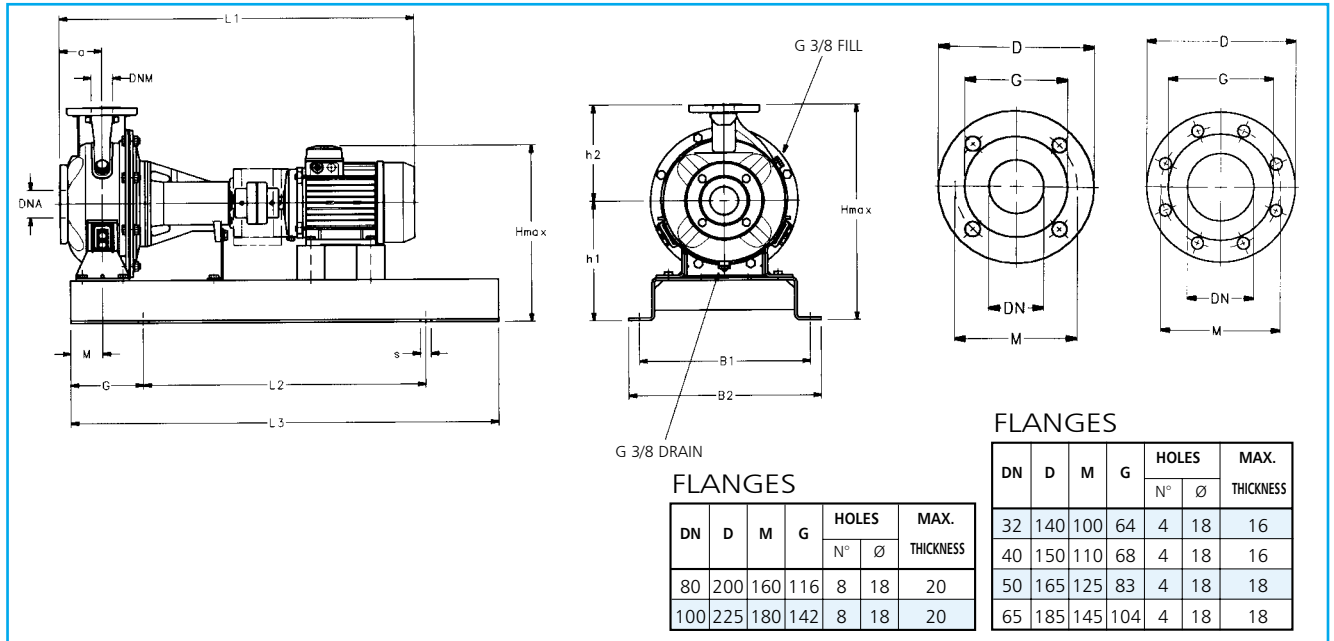

DIMENSIONS AND WEIGHTS SHF4 SERIES, 4 POLES

PUMP TYPE	DIMENSIONS (mm)													s for screws	WEIGHT kg
	DNM	DNA	a	B1	B2	L1	L2	L3	G	M	h1	h2	Hmax		
SHF4 25-125/02A	25	50	80	320	360	702	540	800	130	60	212	140	352	M16	72
SHF4 25-125/02	25	50	80	320	360	702	540	800	130	60	212	140	352	M16	72
SHF4 25-160/02	25	50	80	320	360	702	540	800	130	60	232	160	392	M16	74
SHF4 25-160/03	25	50	80	320	360	702	540	800	130	60	232	160	392	M16	76
SHF4 25-200/03	25	50	80	320	360	702	540	800	130	60	260	180	440	M16	78
SHF4 25-200/05	25	50	80	320	360	744	540	800	130	60	260	180	440	M16	80
SHF4 25-250/07	25	50	100	400	450	764	660	1000	170	75	280	225	505	M20	97
SHF4 25-250/11	25	50	100	400	450	793	660	1000	170	75	280	225	505	M20	100
SHF4 25-250/15	25	50	100	400	450	793	660	1000	170	75	280	225	505	M20	102
SHF4 32-125/02A	32	50	80	320	360	702	540	800	130	60	212	140	352	M16	72
SHF4 32-125/02	32	50	80	320	360	702	540	800	130	60	212	140	352	M16	72
SHF4 32-160/02	32	50	80	320	360	702	540	800	130	60	232	160	392	M16	74
SHF4 32-160/03	32	50	80	320	360	702	540	800	130	60	232	160	392	M16	76
SHF4 32-200/03	32	50	80	320	360	702	540	800	130	60	260	180	440	M16	78
SHF4 32-200/05	32	50	80	320	360	744	540	800	130	60	260	180	440	M16	80
SHF4 32-250/07	32	50	100	400	450	764	660	1000	170	75	280	225	505	M20	97
SHF4 32-250/11	32	50	100	400	450	793	660	1000	170	75	280	225	505	M20	100
SHF4 32-250/15	32	50	100	400	450	793	660	1000	170	75	280	225	505	M20	102
SHF4 40-125/02A	40	65	80	320	360	702	540	800	130	60	212	140	352	M16	57
SHF4 40-125/02	40	65	80	320	360	702	540	800	130	60	212	140	352	M16	57
SHF4 40-125/03	40	65	80	320	360	702	540	800	130	60	212	140	352	M16	58
SHF4 40-160/03	40	65	80	320	360	702	540	800	130	60	232	160	392	M16	60
SHF4 40-160/05	40	65	80	320	360	744	540	800	130	60	232	160	392	M16	62
SHF4 40-200/07	40	65	100	350	390	764	600	900	150	60	260	180	440	M16	69
SHF4 40-200/11	40	65	100	350	390	793	600	900	150	60	260	180	440	M16	72
SHF4 40-250/11	40	65	100	400	450	793	660	1000	170	75	280	225	505	M20	99
SHF4 40-250/15	40	65	100	400	450	793	660	1000	170	75	280	225	505	M20	102
SHF4 40-250/22	40	65	100	400	450	829	660	1000	170	75	280	225	505	M20	115
SHF4 50-125/03A	50	65	100	320	360	722	540	800	130	60	232	160	392	M16	59
SHF4 50-125/03	50	65	100	320	360	722	540	800	130	60	232	160	392	M16	59
SHF4 50-125/05	50	65	100	320	360	764	540	800	130	60	260	180	440	M16	61
SHF4 50-160/07	50	65	100	350	390	764	600	900	150	60	260	180	440	M16	68
SHF4 50-160/11	50	65	100	350	390	793	600	900	150	60	260	200	460	M16	71
SHF4 50-200/11	50	65	100	350	390	793	600	900	150	60	260	200	460	M16	82
SHF4 50-200/15	50	65	100	350	390	793	600	900	150	60	260	200	460	M16	85
SHF4 50-250/22A	50	65	100	400	450	829	660	1000	170	75	280	225	505	M20	116
SHF4 50-250/22	50	65	100	400	450	829	660	1000	170	75	280	225	505	M20	116
SHF4 50-250/30	50	65	100	400	450	829	660	1000	170	75	280	225	505	M20	120
SHF4 65-160/05	65	80	100	350	390	764	600	900	150	75	260	200	460	M16	84
SHF4 65-160/07	65	80	100	350	390	764	600	900	150	75	260	200	460	M16	85
SHF4 65-160/11A	65	80	100	400	450	793	660	1000	170	75	260	200	460	M20	88
SHF4 65-160/11	65	80	100	400	450	793	660	1000	170	75	260	200	460	M20	88
SHF4 65-160/15	65	80	100	400	450	793	660	1000	170	75	260	200	460	M20	91
SHF4 65-200/15	65	80	100	400	450	793	660	1000	170	75	280	225	505	M20	103
SHF4 65-200/22	65	80	100	440	490	829	740	1120	190	75	280	225	505	M20	117
SHF4 65-200/30	65	80	100	440	490	829	740	1120	190	75	280	225	505	M20	121
SHF4 65-250/40	65	80	100	440	490	962	740	1120	190	90	310	250	550	M20	158
SHF4 65-250/55	65	80	100	440	490	1019	740	1120	190	90	310	250	550	M20	174
SHF4 80-160/15	80	100	125	400	450	818	660	1000	170	75	280	225	505	M20	121
SHF4 80-160/22A	80	100	125	440	490	854	740	1120	190	75	280	225	505	M20	127
SHF4 80-160/22	80	100	125	440	490	854	740	1120	190	75	280	225	505	M20	127
SHF4 80-200/30	80	100	125	440	490	964	740	1120	190	75	280	250	530	M20	146
SHF4 80-200/40	80	100	125	440	490	987	740	1120	190	75	280	250	530	M20	151
SHF4 80-250/55	80	100	125	490	540	1044	840	1250	205	90	310	280	580	M20	175
SHF4 80-250/75	80	100	125	490	540	1082	840	1250	205	90	310	280	580	M20	185
SHF4 80-250/92	80	100	125	490	540	1082	840	1250	205	90	310	280	580	M20	185

SH

SHF BARE SHAFT SERIES DIMENSIONS AND WEIGHTS

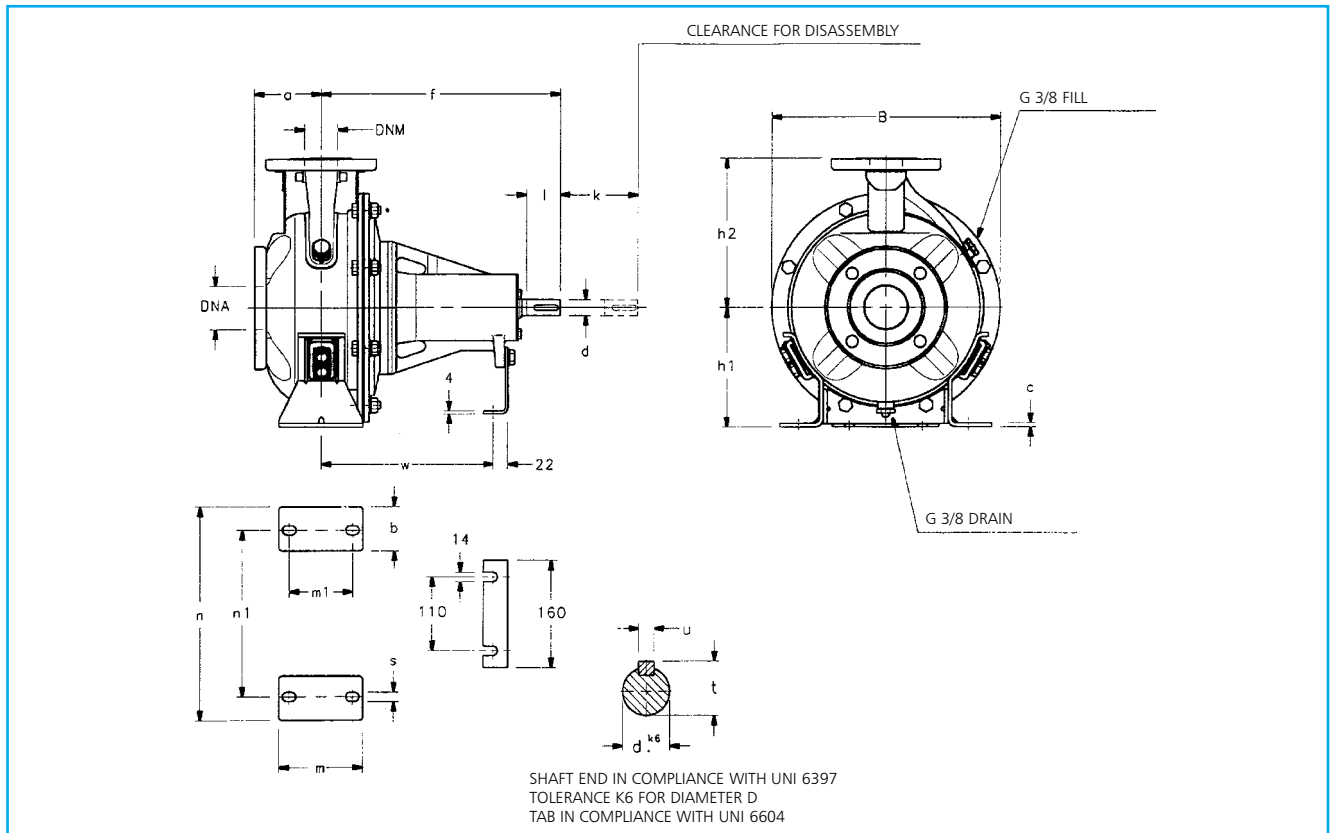

PUMP TYPE	DIMENSIONS (mm)								B	k	WEIGHT kg
	DNM	DNA	a	d	f	h1	h2				
SHF 32-125	32	50	80	24	360	112	140	218	98	16	
SHF 32-160	32	50	80	24	360	132	160	253	98	18	
SHF 32-200	32	50	80	24	360	160	180	285	98	20	
SHF 32-250	32	50	100	24	360	180	225	345	98	36	
SHF 40-125	40	65	80	24	360	112	140	219	100	17	
SHF 40-160	40	65	80	24	360	132	160	254	100	18	
SHF 40-200	40	65	100	24	360	160	180	285	100	20	
SHF 40-250	40	65	100	24	360	180	225	345	100	36	
SHF 50-125	50	65	100	24	360	132	160	254	100	18	
SHF 50-160	50	65	100	24	360	160	180	255	100	19	
SHF 50-200	50	65	100	24	360	160	200	310	100	30	
SHF 50-250	50	65	100	24	360	180	225	345	100	36	
SHF 65-160	65	80	100	24	360	160	200	310	100	21	
SHF 65-200	65	80	100	24	360	180	225	310	100	31	
SHF 65-250	65	80	100	32	470	200	250	345	130	42	
SHF 80-160	80	100	125	24	360	180	225	345	140	22	
SHF 80-200	80	100	125	32	470	180	250	345	140	37	
SHF 80-250	80	100	125	32	470	200	280	384	140	43	