



GS 4" Series

Multi-stage centrifugal submersible pumps for clean water in 4" wells. High content of AISI 304 stainless steel. The floating impeller design ensures an excellent resistance to wear.

The upper and lower supports are made of precision-cast stainless steel ensuring resistance to corrosion, strength and rigid coupling to the motor. The non-return valve is integrated in the head to support the weight of the column of water and protect against water hammer, thus safeguarding impellers and diffusers. Can also operate in a horizontal position.

SPECIFICATIONS

Delivery: up to 21 m³/h

Head: up to 340 metres

Power supply: three-phase and single-phase 50 and 60 Hz

Single-phase version: 220-240 V, 50Hz

Three-phase version: 380-415 V; overload protection to be provided by user and installed in the control box (see control box section)

Power: 0.25 kW to 7.5 kW

Maximum overall diameter of pump (cable cover included): 99 mm

Water temperature: 0°C to +35°C

Maximum permissible quantity of suspended sand: 150 g/m³

MATERIALS

Valve cap, valve seat: Stainless steel

Valve gasket: NBR

Valve stop ring: Stainless steel

Upper support: Technopolymer

Bush bearings: Polyurethane

Impeller, diffuser: Technopolymer

Diffuser case, shim, pump shaft, outer sleeve, spacer, filter, coupling, cable cover:

Stainless Steel

APPLICATIONS

- Water supply
- Pressure boosting
- Irrigation
- Rain water collection
- Fire-fighting



For a complete list of technical information, consult www.lowara.com

Engineered for life



General Catalogue

1GSL SERIES

HYDRAULIC PERFORMANCE TABLE AT 50 Hz

PUMP TYPE	N. OF STAGES	MOTOR POWER		Q = DELIVERY					
		kW	HP	l/min	8,3	10	15	20	22,5
				m ³ /h	0	0,5	0,6	0,9	1,2
H = TOTAL HEAD METRES COLUMN OF WATER									
1GSL02 ⁽¹⁾	8	0,37	0,5	53	46,6	45	37	27	20,6
1GSL03	12	0,37	0,5	79,4	69,9	67	55	40	30,9
1GSL05	18	0,55	0,75	119	105	100	83	60	46,3
1GSL07	24	0,75	1	159	140	133	110	80	61,7
1GSL11	35	1,1	1,5	232	204	194	160	116	90
1GSL15	49	1,5	2	324	285	272	224	163	126

(1) Maximum pump absorbed power: 0,25 kW - 0,33 HP.

1gsl-2p50-en_c_td

1GSL..40S SERIES

DIMENSIONS AND WEIGHTS

ELECTRIC PUMP TYPE *	NUMBER OF STAGES	DNM	DIMENSIONS (mm)		WEIGHT PUMP kg	ELECTRIC PUMP WEIGHT kg
			L1	L		
1GSL02M-40S	8	Rp 1 1/4	298	651	3,1	10,7
1GSL03M-40S	12	Rp 1 1/4	369	722	3,9	11,5
1GSL05M-40S	18	Rp 1 1/4	472	825	4,9	13,1
1GSL07M-40S	24	Rp 1 1/4	578	956	5,8	15,1
1GSL11M-40S	35	Rp 1 1/4	824	1237	8,7	19,9
1GSL15M-40S	49	Rp 1 1/4	1068	1516	11,8	24,6
1GSL03T-40S	12	Rp 1 1/4	369	701	3,9	11
1GSL05T-40S	18	Rp 1 1/4	472	825	4,9	12,5
1GSL07T-40S	24	Rp 1 1/4	578	931	5,8	14
1GSL11T-40S	35	Rp 1 1/4	824	1202	8,7	18
1GSL15T-40S	49	Rp 1 1/4	1068	1481	11,8	23,2

1gsl-40s-2p50_a_td

1GSL..L4C SERIES

DIMENSIONS AND WEIGHTS

ELECTRIC PUMP TYPE	NUMBER OF STAGES	DNM	DIMENSIONS (mm)		PUMP WEIGHT kg	ELECTRIC PUMP WEIGHT kg
			L1	L		
1GSL02M-L4C	8	Rp 1 1/4	298	532	3,1	10,3
1GSL03M-L4C	12	Rp 1 1/4	369	603	3,9	11,2
1GSL05M-L4C	18	Rp 1 1/4	472	736	4,9	12,7
1GSL07M-L4C	24	Rp 1 1/4	578	862	5,8	14,2
1GSL11M-L4C	35	Rp 1 1/4	824	1153	8,7	19,6
1GSL15M-L4C	49	Rp 1 1/4	1068	1459	11,8	24,5
1GSL03T-L4C	12	Rp 1 1/4	369	583	3,9	10,9
1GSL05T-L4C	18	Rp 1 1/4	472	706	4,9	12,1
1GSL07T-L4C	24	Rp 1 1/4	578	842	5,8	13,6
1GSL11T-L4C	35	Rp 1 1/4	824	1108	8,7	17,1
1GSL15T-L4C	49	Rp 1 1/4	1068	1414	11,8	23,8

1gsl-l4c-2p50_a_td

* Electric pumps over 1500 mm long are supplied uncoupled. Motor and pump are packed separately.

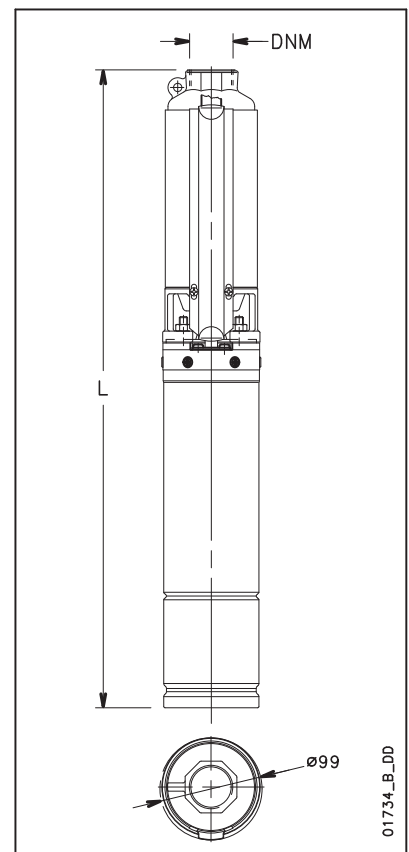
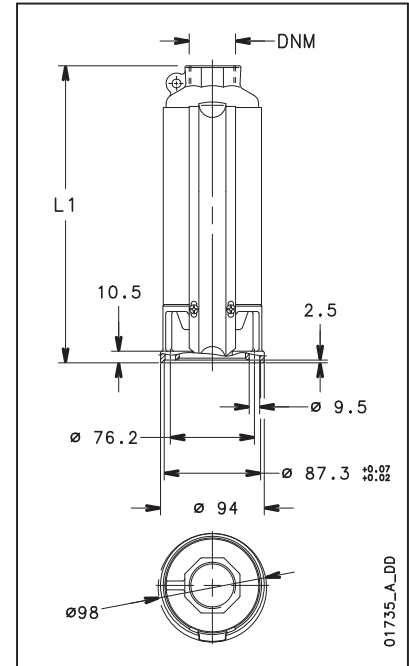

Engineered for life



General Catalogue

1GSL SERIES

OPERATING CHARACTERISTICS AT 50 Hz

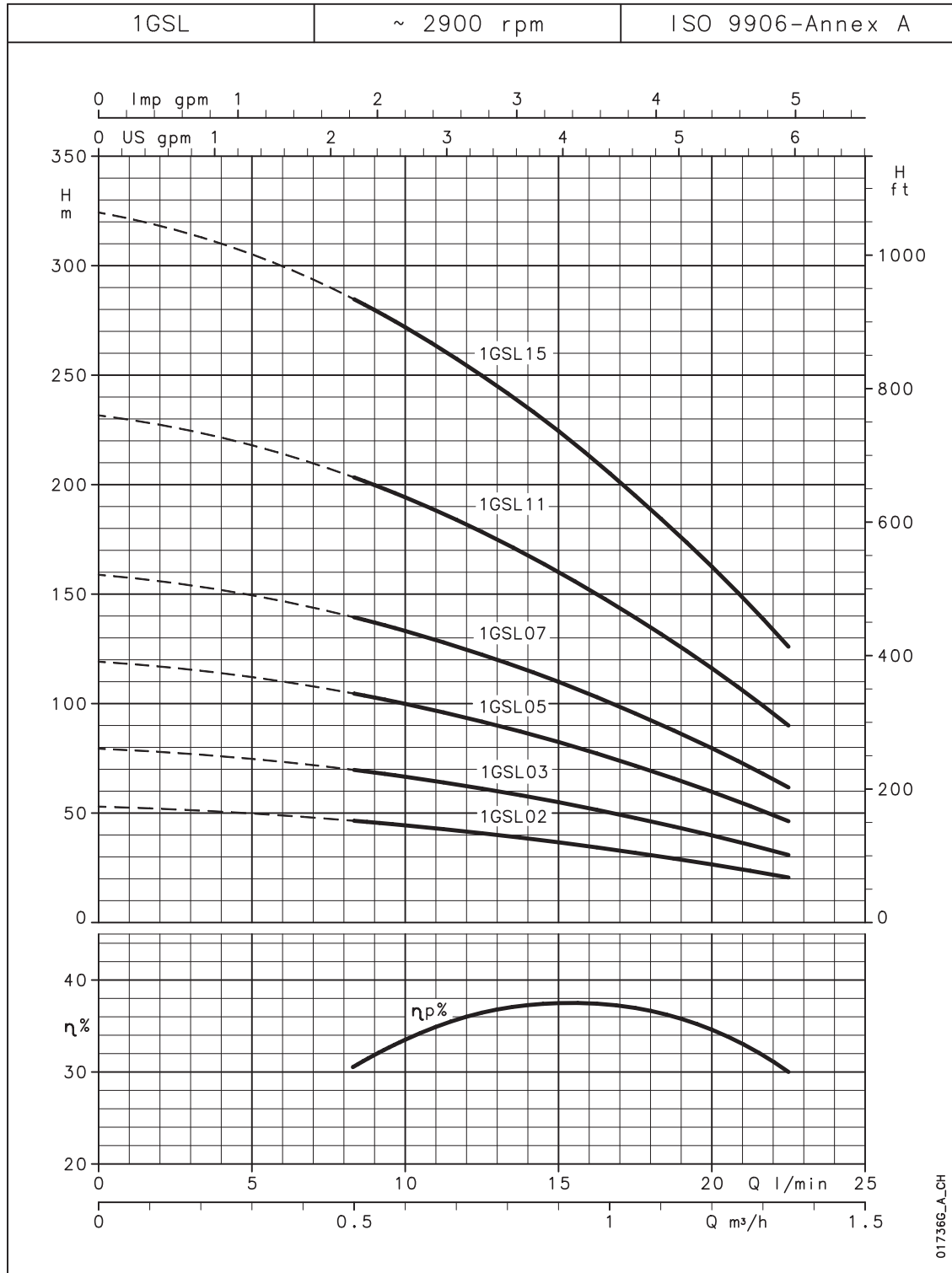

These performances are valid for liquids with density $\rho = 1.0 \text{ kg/dm}^3$ and kinematic viscosity $\nu = 1 \text{ mm}^2/\text{s}$.

Engineered for life



General Catalogue

2GS SERIES – HYDRAULIC PERFORMANCE TABLE AT 50 Hz

PUMP TYPE	N. OF STAGES	MOTOR POWER		Q = DELIVERY						
				v/min	0	20	25	30	40	50
				m ³ /h	0	1,2	1,5	1,8	2,4	3
				H = TOTAL HEAD METRES COLUMN OF WATER						
2GS02 ⁽¹⁾	5	0,37	0,5	33	30	28	26	20	13	
2GS03	7	0,37	0,5	47	42	40	36	29	19	
2GS05	10	0,55	0,75	67	60	56	52	41	27	
2GS07	14	0,75	1	93	83	79	73	57	37	
2GS11	20	1,1	1,5	133	119	113	104	82	53	
2GS15	28	1,5	2	187	167	158	146	115	74	
2GS22	40	2,2	3	267	238	226	208	164	106	
2GS30	52	3	4	347	309	294	271	213	138	

(1) Maximum pump absorbed power: 0,25 kW - 0,33 HP.

2gs-2p50-en_c_th

2GS..40S SERIES – DIMENSIONS AND WEIGHTS

ELECTRIC PUMP TYPE *	NUMBER OF STAGES	DNM	DIMENSIONS (mm)		PUMP WEIGHT kg	ELECTRIC PUMP WEIGHT kg
			L1	L		
			2GS02M-40S	5		
2GS03M-40S	7	Rp 1 1/4	280	633	2,9	10,5
2GS05M-40S	10	Rp 1 1/4	332	685	3,5	11,7
2GS07M-40S	14	Rp 1 1/4	402	780	4,2	13,5
2GS11M-40S	20	Rp 1 1/4	507	920	5,3	16,5
2GS15M-40S	28	Rp 1 1/4	680	1128	7,1	19,9
2GS22M-40S	40	Rp 1 1/4	914	1412	10,1	25,2
2GS03T-40S	7	Rp 1 1/4	280	612	2,9	10
2GS05T-40S	10	Rp 1 1/4	332	685	3,5	11,1
2GS07T-40S	14	Rp 1 1/4	402	755	4,2	12,4
2GS11T-40S	20	Rp 1 1/4	507	885	5,3	14,6
2GS15T-40S	28	Rp 1 1/4	680	1093	7,1	18,5
2GS22T-40S	40	Rp 1 1/4	914	1362	10,1	23
2GS30T-40S	52	Rp 1 1/4	1120	1568	12,2	26,1

2gs-4os-2p50_a_td

2GS..L4C SERIES – DIMENSIONS AND WEIGHTS

ELECTRIC PUMP TYPE *	NUMBER OF STAGES	DNM	DIMENSIONS (mm)		PUMP WEIGHT kg	ELECTRIC PUMP WEIGHT kg
			L1	L		
			2GS02M-L4C	5		
2GS03M-L4C	7	Rp 1 1/4	280	514	2,9	10,1
2GS05M-L4C	10	Rp 1 1/4	332	596	3,5	11,3
2GS07M-L4C	14	Rp 1 1/4	402	686	4,2	12,6
2GS11M-L4C	20	Rp 1 1/4	507	836	5,3	16,2
2GS15M-L4C	28	Rp 1 1/4	680	1071	7,1	19,8
2GS22M-L4C	40	Rp 1 1/4	914	1325	10,1	24,3
2GS03T-L4C	7	Rp 1 1/4	280	494	2,9	9,9
2GS05T-L4C	10	Rp 1 1/4	332	566	3,5	10,7
2GS07T-L4C	14	Rp 1 1/4	402	666	4,2	12
2GS11T-L4C	20	Rp 1 1/4	507	791	5,3	13,7
2GS15T-L4C	28	Rp 1 1/4	680	1026	7,1	19,1
2GS22T-L4C	40	Rp 1 1/4	914	1305	10,1	22,9
2GS30T-L4C	52	Rp 1 1/4	1120	1662	12,2	32,8

2gs-l4c-2p50_a_td

* Electric pumps over 1500 mm long are supplied uncoupled.
Motor and pump are packed separately.

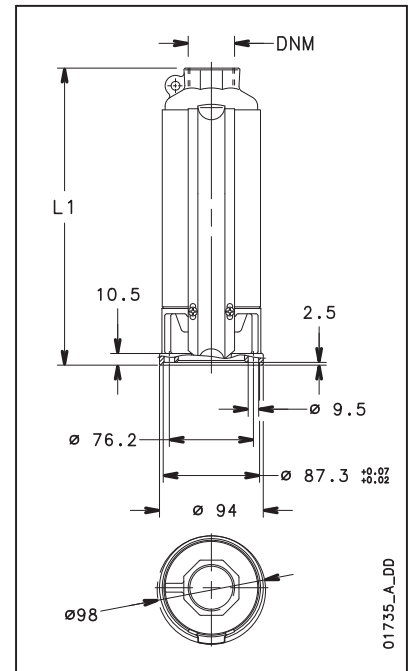

01735_A_DD

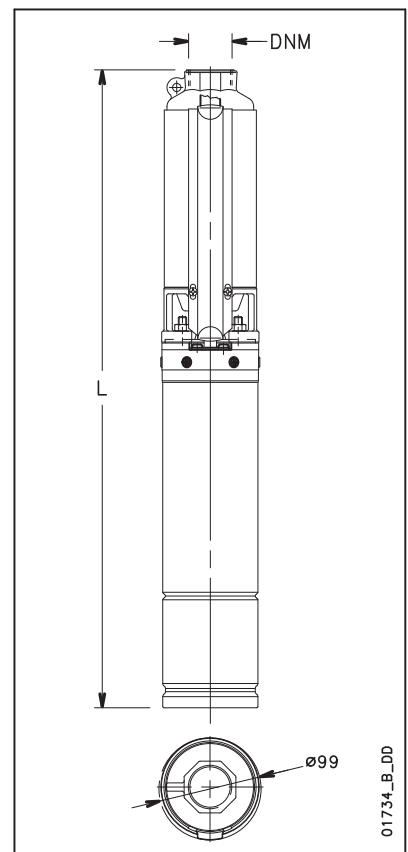

01734_B_DD



General Catalogue

2GS SERIES

OPERATING CHARACTERISTICS AT 50 Hz

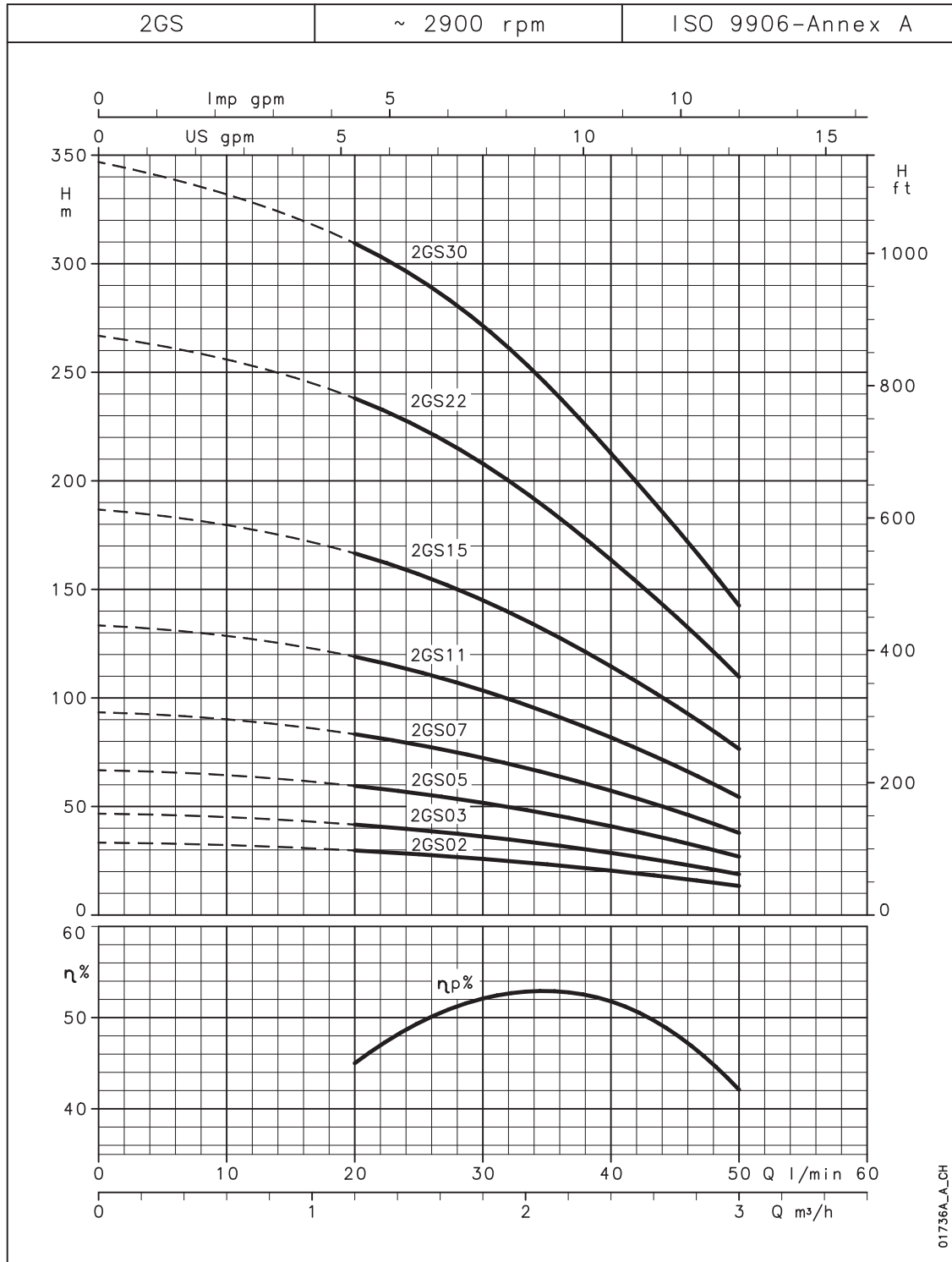

These performances are valid for liquids with density $\rho = 1.0 \text{ kg/dm}^3$ and kinematic viscosity $\nu = 1 \text{ mm}^2/\text{s}$.

Engineered for life



General Catalogue

4GS SERIES – HYDRAULIC PERFORMANCE TABLE AT 50 Hz

PUMP TYPE	NUMBER OF STAGES	RATED POWER		Q = DELIVERY						
				l/min	0	30	40	60	80	90
				m ³ /h	0	1,8	2,4	3,6	4,8	5,4
				H = TOTAL HEAD IN COLUMN OF WATER (METRES)						
4GS03M	4	0,37	0,5	27	24	23	19	13	9	
4GS05M	7	0,55	0,75	47	42	40	33	22	15	
4GS07M	9	0,75	1	60	54	51	42	28	19	
4GS11M	14	1,1	1,5	94	84	80	66	44	30	
4GS15M	19	1,5	2	127	114	108	89	60	40	
4GS22M	27	2,2	3	181	162	154	127	85	57	
4GS30T	35	3	4	228	204	194	160	107	72	
4GS40T	48	4	5,5	321	288	274	226	151	102	

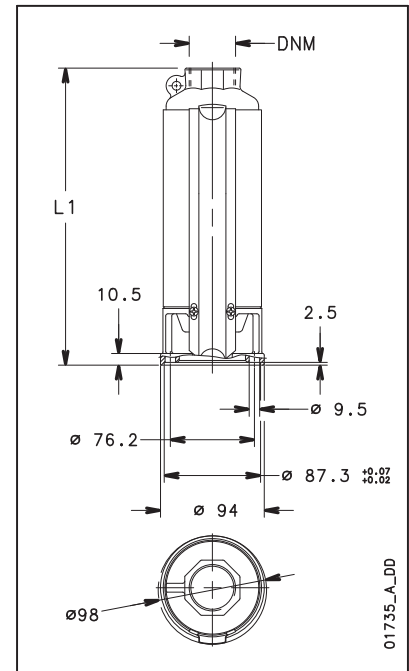

4GS..40S SERIES – DIMENSIONS AND WEIGHTS 4gs-2p50_b_th

ELECTRIC PUMP TYPE *	NUMBER OF STAGES	DNM	DIMENSIONS (mm)		PUMP WEIGHT kg	ELECTRIC PUMP WEIGHT kg
			L1	L		
4GS03M-4OS	4	Rp 1 1/4	245	598	2,5	10,1
4GS05M-4OS	7	Rp 1 1/4	309	662	3,1	11,3
4GS07M-4OS	9	Rp 1 1/4	352	730	3,5	12,8
4GS11M-4OS	14	Rp 1 1/4	460	873	4,6	15,8
4GS15M-4OS	19	Rp 1 1/4	568	1016	5,7	18,5
4GS22M-4OS	27	Rp 1 1/4	770	1268	7,6	22,7
4GS03T-4OS	4	Rp 1 1/4	245	577	2,5	9,6
4GS05T-4OS	7	Rp 1 1/4	309	662	3,1	10,7
4GS07T-4OS	9	Rp 1 1/4	352	705	3,5	11,7
4GS11T-4OS	14	Rp 1 1/4	460	838	4,6	13,9
4GS15T-4OS	19	Rp 1 1/4	568	981	5,7	17,1
4GS22T-4OS	27	Rp 1 1/4	770	1218	7,6	20,5
4GS30T-4OS	35	Rp 1 1/4	967	1415	9,6	23,5
4GS40T-4OS	48	Rp 1 1/4	1248	1816	12,8	30,6

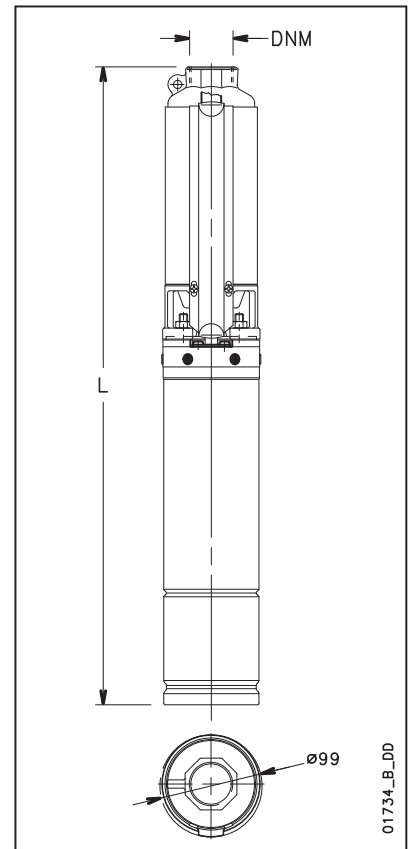

4GS..L4C SERIES – DIMENSIONS AND WEIGHTS 4gs-4os-2p50_a_td

ELECTRIC PUMP TYPE *	NUMBER OF STAGES	DNM	DIMENSIONS (mm)		PUMP WEIGHT kg	ELECTRIC PUMP WEIGHT kg
			L1	L		
4GS03M-L4C	4	Rp 1 1/4	245	479	2,5	9,7
4GS05M-L4C	7	Rp 1 1/4	309	573	3,1	10,9
4GS07M-L4C	9	Rp 1 1/4	352	636	3,5	11,9
4GS11M-L4C	14	Rp 1 1/4	460	789	4,6	15,5
4GS15M-L4C	19	Rp 1 1/4	568	959	5,7	18,4
4GS22M-L4C	27	Rp 1 1/4	770	1181	7,6	21,8
4GS03T-L4C	4	Rp 1 1/4	245	459	2,5	9,5
4GS05T-L4C	7	Rp 1 1/4	309	543	3,1	10,3
4GS07T-L4C	9	Rp 1 1/4	352	616	3,5	11,3
4GS11T-L4C	14	Rp 1 1/4	460	744	4,6	13
4GS15T-L4C	19	Rp 1 1/4	568	914	5,7	17,7
4GS22T-L4C	27	Rp 1 1/4	770	1161	7,6	20,4
4GS30T-L4C	35	Rp 1 1/4	967	1509	9,6	30,2
4GS40T-L4C	48	Rp 1 1/4	1248	1860	12,8	36,5

* Electric pumps over 1500 mm long are supplied uncoupled. Motor and pump are packed separately.

Engineered for life



General Catalogue

4GS SERIES

OPERATING CHARACTERISTICS AT 50 Hz

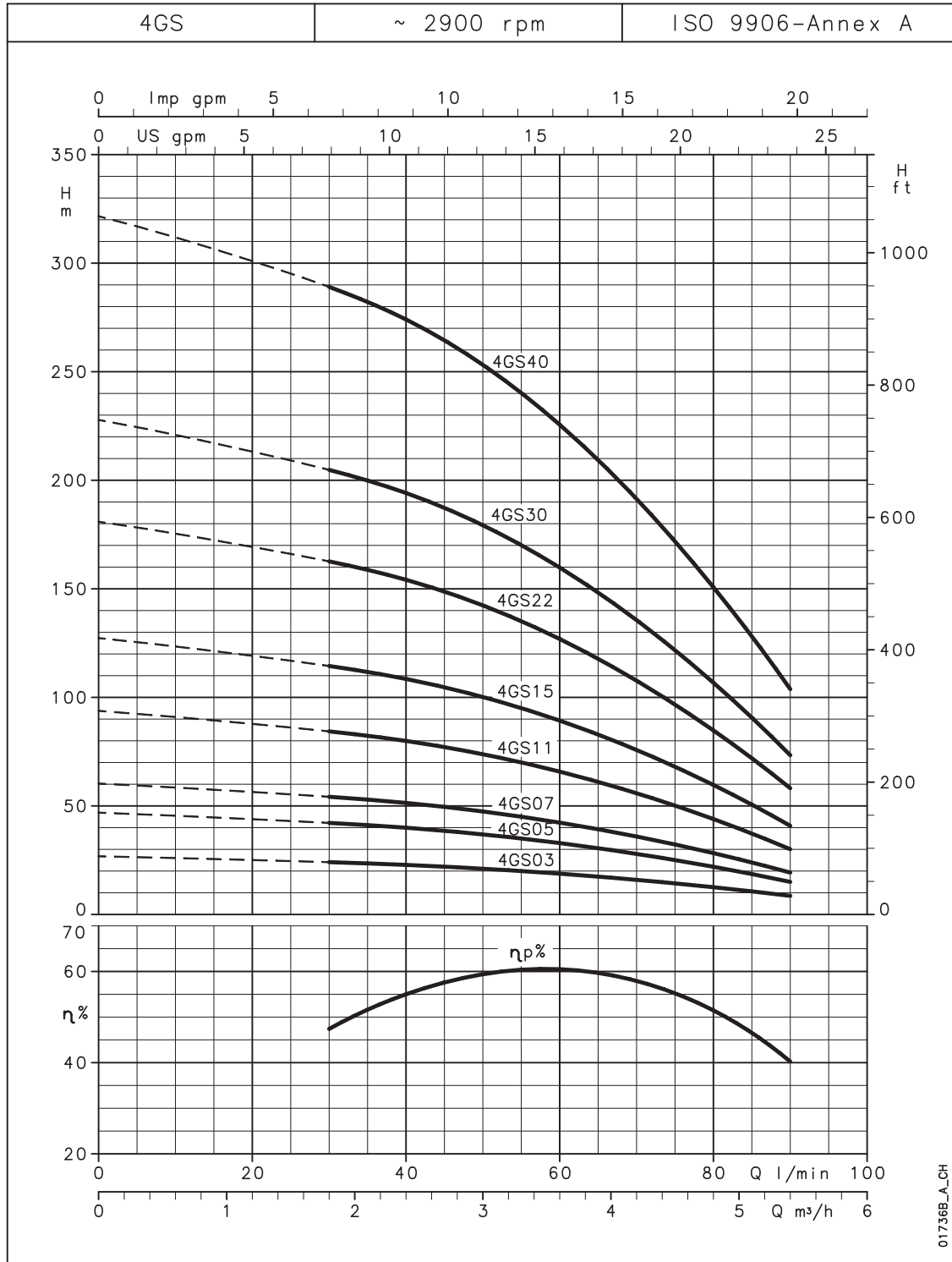

These performances are valid for liquids with density $\rho = 1.0 \text{ kg/dm}^3$ and kinematic viscosity $\nu = 1 \text{ mm}^2/\text{s}$.

Engineered for life



General Catalogue

6GS SERIES – HYDRAULIC PERFORMANCE TABLE AT 50 Hz

PUMP TYPE	NUMBER OF STAGES	RATED POWER		Q = DELIVERY						
				l/min	0	50	70	90	110	133
				m ³ /h	0	3	4,2	5,4	6,6	8
				H = TOTAL HEAD IN COLUMN OF WATER (METRES)						
		kW	HP							
6GS05	5	0,55	0,75	30,5	25,8	23	21	17	11,5	
6GS07	7	0,75	1	42,7	36,1	33	29	24	16,1	
6GS11	10	1,1	1,5	61	51,6	47	41	34	23	
6GS15	14	1,5	2	85,4	72,2	66	58	48	32,2	
6GS22	21	2,2	3	128	108	99	87	71	48,3	
6GS30	29	3,0	4	177	150	136	120	99	66,7	
6GS40	38	4,0	5,5	232	196	179	157	129	87,4	
6GS55	52	5,5	7,5	317	268	244	215	177	120	

6gs-2p50_b_th

6GS..40S SERIES – DIMENSIONS AND WEIGHTS

ELECTRIC PUMP TYPE *	NUMBER OF STAGES	DNM	DIMENSIONS (mm)		PUMP WEIGHT kg	ELECTRIC PUMP WEIGHT kg
			L1	L		
			6GS05M-40S	5		
6GS07M-40S	7	Rp 1 1/4	390	768	4,2	13,5
6GS11M-40S	10	Rp 1 1/4	485	898	5,1	16,3
6GS15M-40S	14	Rp 1 1/4	645	1093	6,8	19,6
6GS22M-40S	21	Rp 1 1/4	862	1360	9,1	24,2
6GS05T-40S	5	Rp 1 1/4	329	682	3,5	11,1
6GS07T-40S	7	Rp 1 1/4	390	743	4,2	12,4
6GS11T-40S	10	Rp 1 1/4	485	863	5,1	14,4
6GS15T-40S	14	Rp 1 1/4	645	1058	6,8	18,2
6GS22T-40S	21	Rp 1 1/4	862	1310	9,1	22
6GS30T-40S	29	Rp 1 1/4	1127	1575	11,8	25,7
6GS40T-40S	38	Rp 1 1/4	1406	1974	14,7	32,5
6GS55T-40S	52	Rp 1 1/4	1840	2468	19,3	40,6

6gs-40s-2p50_a_td

6GS..L4C SERIES – DIMENSIONS AND WEIGHTS

ELECTRIC PUMP TYPE *	NUMBER OF STAGES	DNM	DIMENSIONS (mm)		PUMP WEIGHT kg	ELECTRIC PUMP WEIGHT kg
			L1	L		
			6GS05M-L4C	5		
6GS07M-L4C	7	Rp 1 1/4	390	674	4,2	12,6
6GS11M-L4C	10	Rp 1 1/4	485	814	5,1	16
6GS15M-L4C	14	Rp 1 1/4	645	1036	6,8	19,5
6GS22M-L4C	21	Rp 1 1/4	862	1273	9,1	23,3
6GS05T-L4C	5	Rp 1 1/4	329	563	3,5	10,7
6GS07T-L4C	7	Rp 1 1/4	390	654	4,2	12
6GS11T-L4C	10	Rp 1 1/4	485	769	5,1	13,5
6GS15T-L4C	14	Rp 1 1/4	645	991	6,8	18,8
6GS22T-L4C	21	Rp 1 1/4	862	1253	9,1	21,9
6GS30T-L4C	29	Rp 1 1/4	1127	1669	11,8	32,4
6GS40T-L4C	38	Rp 1 1/4	1406	2018	14,7	38,4
6GS55T-L4C	52	Rp 1 1/4	1840	2522	19,3	46,3

6gs-l4c-2p50_a_td

* Electric pumps over 1500 mm long are supplied uncoupled. Motor and pump are packed separately.

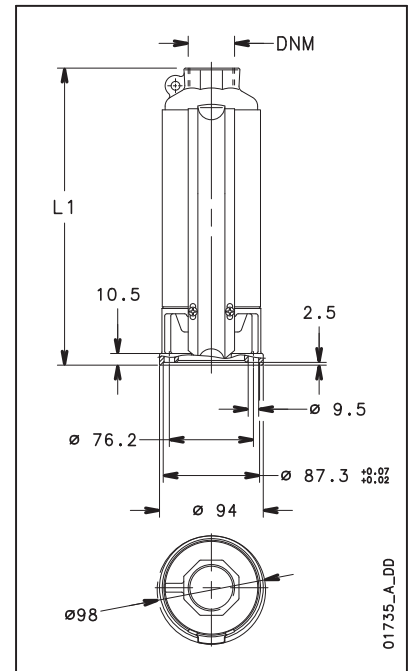

01735_A_DD

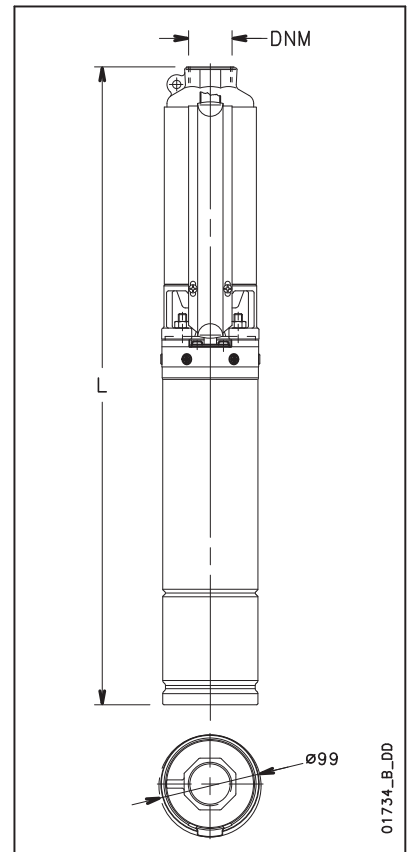

01734_B_DD

Engineered for life



General Catalogue

6GS SERIES

OPERATING CHARACTERISTICS AT 50 Hz

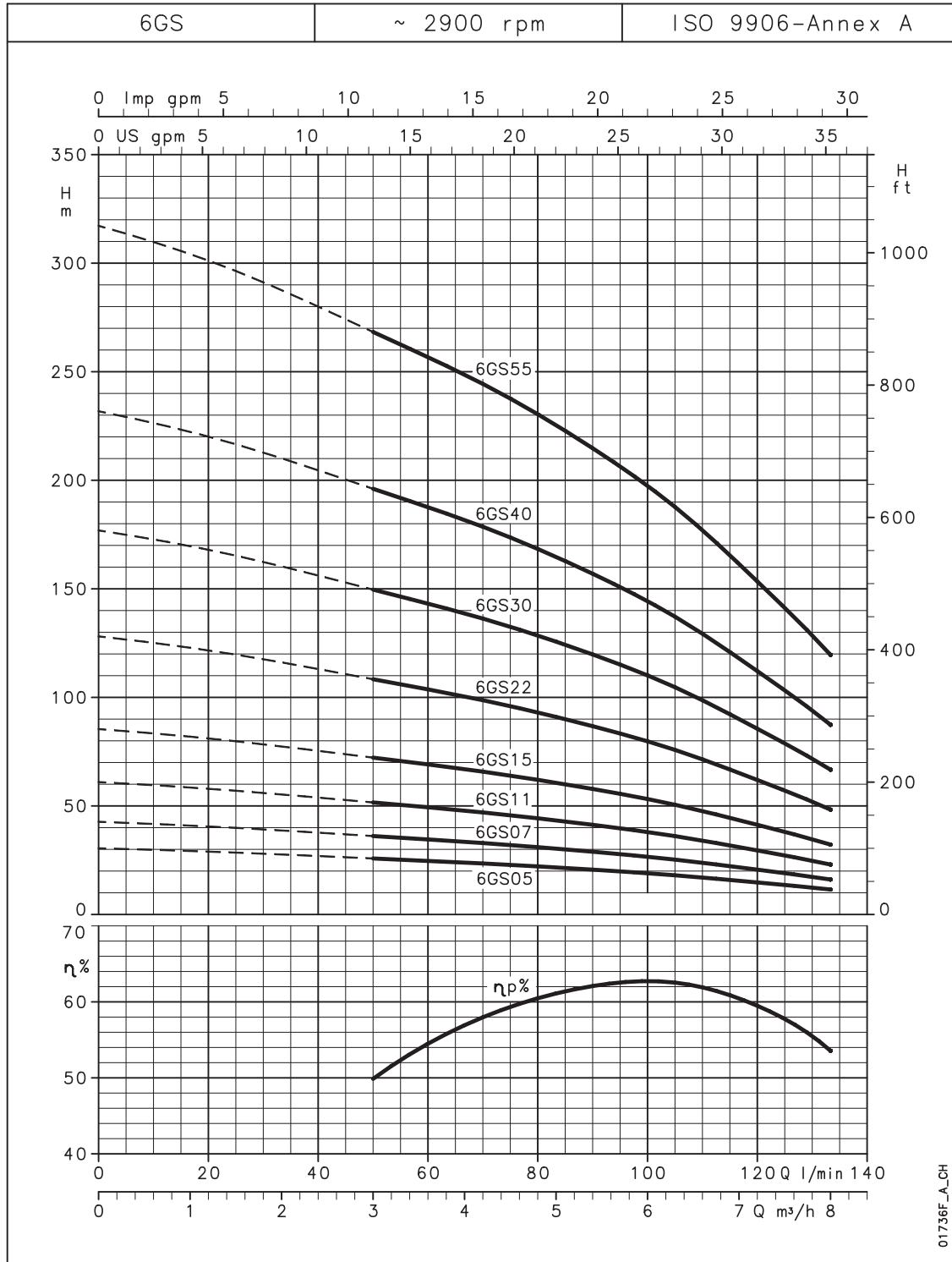

These performances are valid for liquids with density $\rho = 1.0 \text{ kg/dm}^3$ and kinematic viscosity $\nu = 1 \text{ mm}^2/\text{s}$.

Engineered for life



General Catalogue

8GS SERIES – HYDRAULIC PERFORMANCE TABLE AT 50 Hz

PUMP TYPE	NUMBER OF STAGES	RATED POWER		Q = DELIVERY						
				l/min	0	67	100	120	140	183
				m ³ /h	0	4	6	7,2	8,4	11
		kW	HP	H = TOTAL HEAD IN COLUMN OF WATER (METRES)						
				26	23	22	20	18	11	
8GS07	4	0,75	1	26	23	22	20	18	11	
8GS11	6	1,1	1,5	39	35	33	31	28	17	
8GS15	8	1,5	2	52	46	44	41	37	22	
8GS22	13	2,2	3	85	75	71	67	60	36	
8GS30	17	3	4	111	98	93	87	78	47	
8GS40	23	4	5,5	150	133	126	118	106	63	
8GS55	32	5,5	7,5	208	185	175	164	147	88	
8GS75	43	7,5	10	280	249	235	220	198	118	

8gs-2p50_c_th

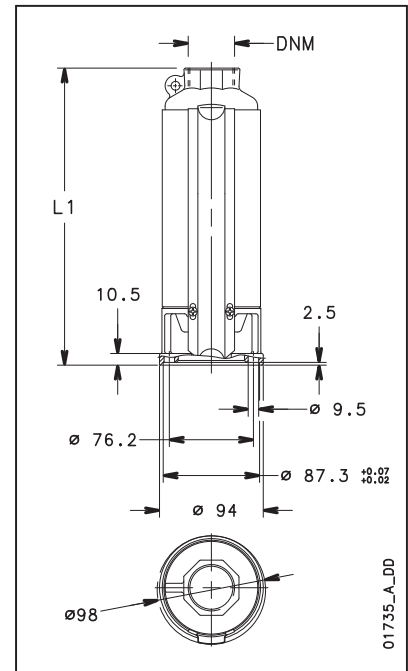

01735_A_DD

8GS..40S SERIES – DIMENSIONS AND WEIGHTS

ELECTRIC PUMP TYPE *	NUMBER OF STAGES	DNM	DIMENSIONS (mm)		PUMP WEIGHT kg	ELECTRIC PUMP WEIGHT kg
			L1	L		
8GS07M-40S	4	Rp 2	299	677	3,2	12,5
8GS11M-40S	6	Rp 2	361	774	3,8	15
8GS15M-40S	8	Rp 2	423	871	4,5	17,3
8GS22M-40S	13	Rp 2	580	1078	6	21,1
8GS07T-40S	4	Rp 2	299	652	3,2	11,4
8GS11T-40S	6	Rp 2	361	739	3,8	13,1
8GS15T-40S	8	Rp 2	423	836	4,5	15,9
8GS22T-40S	13	Rp 2	580	1028	6	18,9
8GS30T-40S	17	Rp 2	740	1188	7,8	21,7
8GS40T-40S	23	Rp 2	926	1494	9,6	27,4
8GS55T-40S	32	Rp 2	1224	1852	12,8	34,1
8GS75T-40S	43	Rp 2	1563	2397	16,2	45

8gs-40s-2p50_a_td

8GS..L4C SERIES – DIMENSIONS AND WEIGHTS

ELECTRIC PUMP TYPE *	NUMBER OF STAGES	DNM	DIMENSIONS (mm)		PUMP WEIGHT kg	ELECTRIC PUMP WEIGHT kg
			L1	L		
8GS07M-L4C	4	Rp 2	299	583	3,2	11,6
8GS11M-L4C	6	Rp 2	361	690	3,8	14,7
8GS15M-L4C	8	Rp 2	423	814	4,5	17,2
8GS22M-L4C	13	Rp 2	580	991	6	20,2
8GS07T-L4C	4	Rp 2	299	563	3,2	11
8GS11T-L4C	6	Rp 2	361	645	3,8	12,2
8GS15T-L4C	8	Rp 2	423	769	4,5	16,5
8GS22T-L4C	13	Rp 2	580	971	6	18,8
8GS30T-L4C	17	Rp 2	740	1282	7,8	28,4
8GS40T-L4C	23	Rp 2	926	1538	9,6	33,3
8GS55T-L4C	32	Rp 2	1224	1906	12,8	39,8
8GS75T-L4C	43	Rp 2	1563	2325	16,2	45,4

8gs-l4c-2p50_a_td

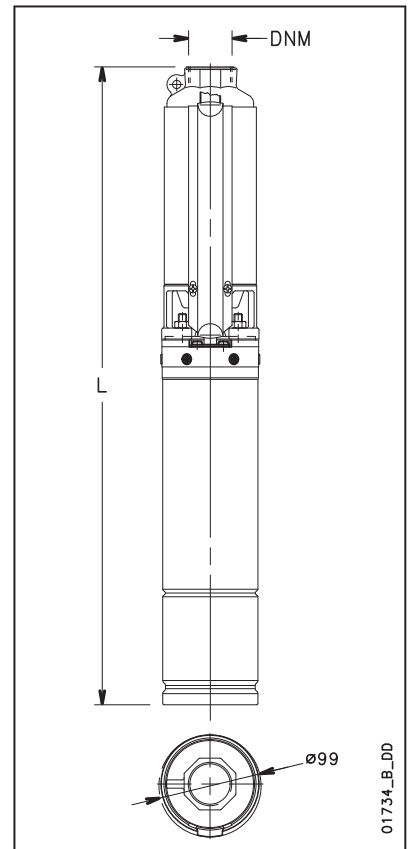

01734_B_DD

* Electric pumps over 1500 mm long are supplied uncoupled. Motor and pump are packed separately.

Engineered for life



General Catalogue

8GS SERIES OPERATING CHARACTERISTICS AT 50 Hz

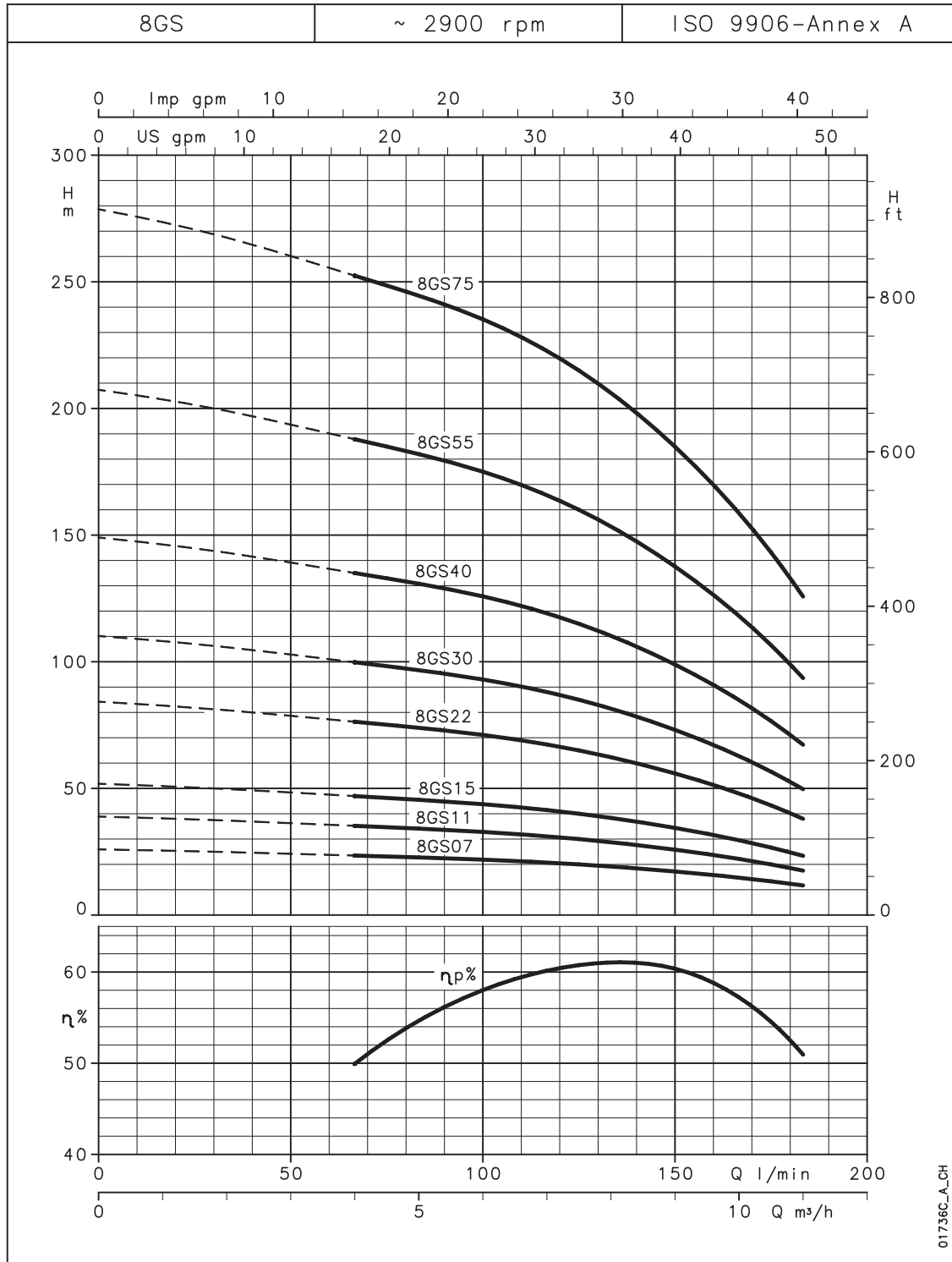

These performances are valid for liquids with density $\rho = 1.0 \text{ kg/dm}^3$ and kinematic viscosity $\nu = 1 \text{ mm}^2/\text{s}$.

Engineered for life



General Catalogue

12GS SERIES

HYDRAULIC PERFORMANCE TABLE AT 50 Hz

PUMP TYPE	NUMBER OF STAGES	RATED POWER		Q = DELIVERY					
		kW	HP	l/min	m ³ /h				
				0	100	150	175	200	250
				0	6	9	10,5	12	15
H = TOTAL HEAD IN COLUMN OF WATER (METRES)									
12GS15	7	1,5	2	43,9	37,3	31	28	24	14,6
12GS22	11	2,2	3	69	58,4	49	43	37	22,5
12GS30	15	3	4	94	79,4	67	59	50	30
12GS40	20	4	5,5	128,6	109,9	94	84	73	46
12GS55	27	5,5	7,5	173,6	148,3	127	113	98	62
12GS75	35	7,5	10	221,8	190,2	163	146	126	80

12gs-2p50_b_th

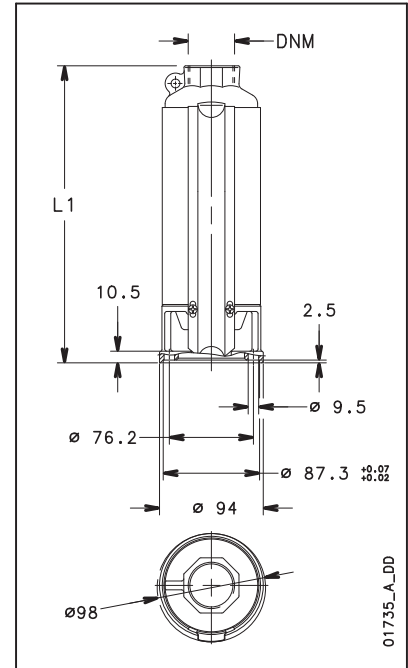

12GS..40S SERIES

DIMENSIONS AND WEIGHTS

ELECTRIC PUMP TYPE *	NUMBER OF STAGES	DNM	DIMENSIONS (mm)		PUMP WEIGHT kg	ELECTRIC PUMP WEIGHT kg
			L1	L		
12GS15M-40S	7	Rp 2	539	987	5,2	18
12GS22M-40S	11	Rp 2	785	1283	7,9	23
12GS15T-40S	7	Rp 2	539	952	5,2	16,6
12GS22T-40S	11	Rp 2	785	1233	7,9	20,8
12GS30T-40S	15	Rp 2	992	1440	10	23,9
12GS40T-40S	20	Rp 2	1252	1820	12,6	30,4
12GS55T-40S	27	Rp 2	1634	2262	16,8	38,1
12GS75T-40S	35	Rp 2	2049	2883	20,9	49,7

12gs-4os-2p50_a_td

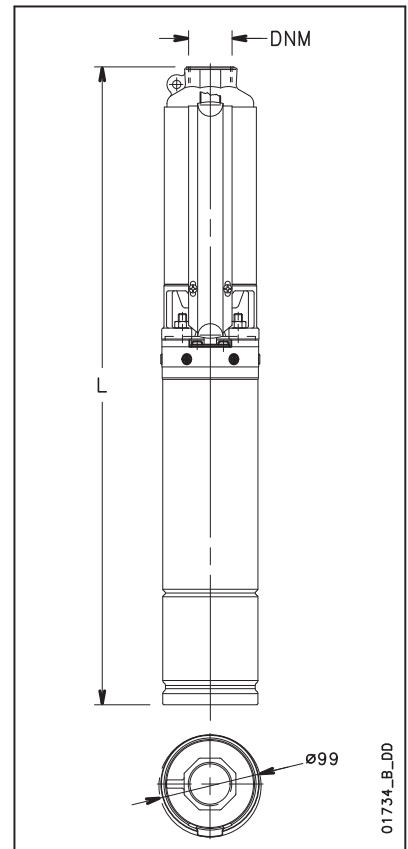

12GS..L4C SERIES

DIMENSIONS AND WEIGHTS

ELECTRIC PUMP TYPE *	NUMBER OF STAGES	DNM	DIMENSIONS (mm)		PUMP WEIGHT kg	ELECTRIC PUMP WEIGHT kg
			L1	L		
12GS15M-L4C	7	Rp 2	539	930	5,2	17,9
12GS22M-L4C	11	Rp 2	785	1196	7,9	22,1
12GS15T-L4C	7	Rp 2	539	885	5,2	17,2
12GS22T-L4C	11	Rp 2	785	1176	7,9	20,7
12GS30T-L4C	15	Rp 2	992	1534	10	30,6
12GS40T-L4C	20	Rp 2	1252	1864	12,6	36,3
12GS55T-L4C	27	Rp 2	1634	2316	16,8	43,8
12GS75T-L4C	35	Rp 2	2049	2811	20,9	50,1

12gs-l4c-2p50_a_td

* Electric pumps over 1500 mm long are supplied uncoupled. Motor and pump are packed separately.

Engineered for life



General Catalogue

12GS SERIES

OPERATING CHARACTERISTICS AT 50 Hz

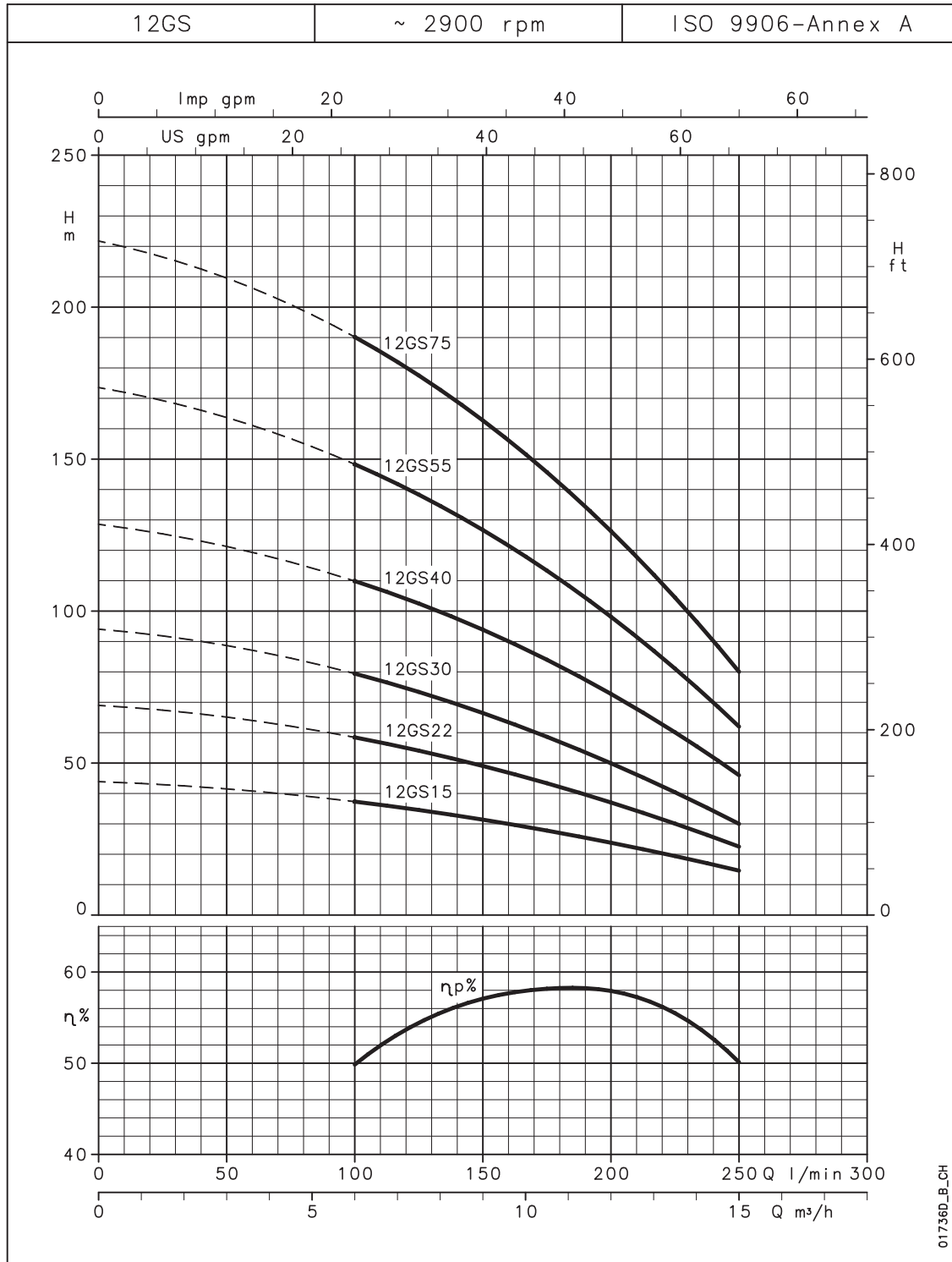

These performances are valid for liquids with density $\rho = 1.0 \text{ kg/dm}^3$ and kinematic viscosity $\nu = 1 \text{ mm}^2/\text{s}$.

Engineered for life



General Catalogue

16GS SERIES

HYDRAULIC PERFORMANCE TABLE AT 50 Hz

PUMP TYPE	NUMBER OF STAGES	RATED POWER		Q = DELIVERY						
				H = TOTAL HEAD IN COLUMN OF WATER (METRES)						
				l/min	0	133	200	250	300	367
				m ³ /h	0	8	12	15	18	22
		kW	HP							
16GS22	9	2,2	3	49,5	40,3	34	29	23	14	
16GS30	12	3	4	66	54	46	39	31	20,4	
16GS40	16	4	5,5	92,1	74,9	64	54	44	29	
16GS55	21	5,5	7,5	120,9	98,6	84	72	59	39	
16GS75	28	7,5	10	161,2	131,5	112	96	78	52	

16gs-2p50_b_th

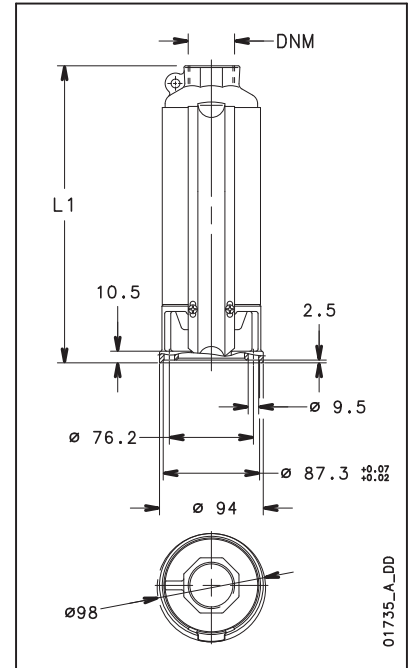

01735_A_DD

16GS..40S SERIES

DIMENSIONS AND WEIGHTS

ELECTRIC PUMP TYPE *	NUMBER OF STAGES	DNM	DIMENSIONS (mm)		PUMP WEIGHT kg	ELECTRIC PUMP WEIGHT kg
			L1	L		
			16GS22M-40S	9		
16GS22T-40S	9	Rp 2	749	1197	7,7	20,6
16GS30T-40S	12	Rp 2	953	1401	9,7	23,6
16GS40T-40S	16	Rp 2	1224	1792	12,4	30,2
16GS55T-40S	21	Rp 2	1620	2248	16,5	37,8
16GS75T-40S	28	Rp 2	2096	2930	21,2	50

16gs-4os-2p50_a_td

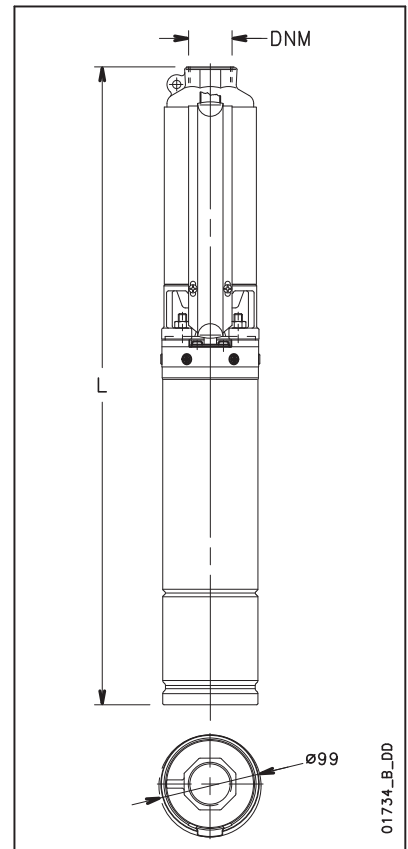

01734_B_DD

16GS..L4C SERIES

DIMENSIONS AND WEIGHTS

ELECTRIC PUMP TYPE *	NUMBER OF STAGES	DNM	DIMENSIONS (mm)		PUMP WEIGHT kg	ELECTRIC PUMP WEIGHT kg
			L1	L		
			16GS22M-L4C	9		
16GS22T-L4C	9	Rp 2	749	1140	7,7	20,5
16GS30T-L4C	12	Rp 2	953	1495	9,7	30,3
16GS40T-L4C	16	Rp 2	1224	1836	12,4	36,1
16GS55T-L4C	21	Rp 2	1620	2302	16,5	43,5
16GS75T-L4C	28	Rp 2	2096	2858	21,2	50,4

16gs-l4c-2p50_a_td

* Electric pumps over 1500 mm long are supplied uncoupled. Motor and pump are packed separately.

Engineered for life



General Catalogue

16GS SERIES

OPERATING CHARACTERISTICS AT 50 Hz

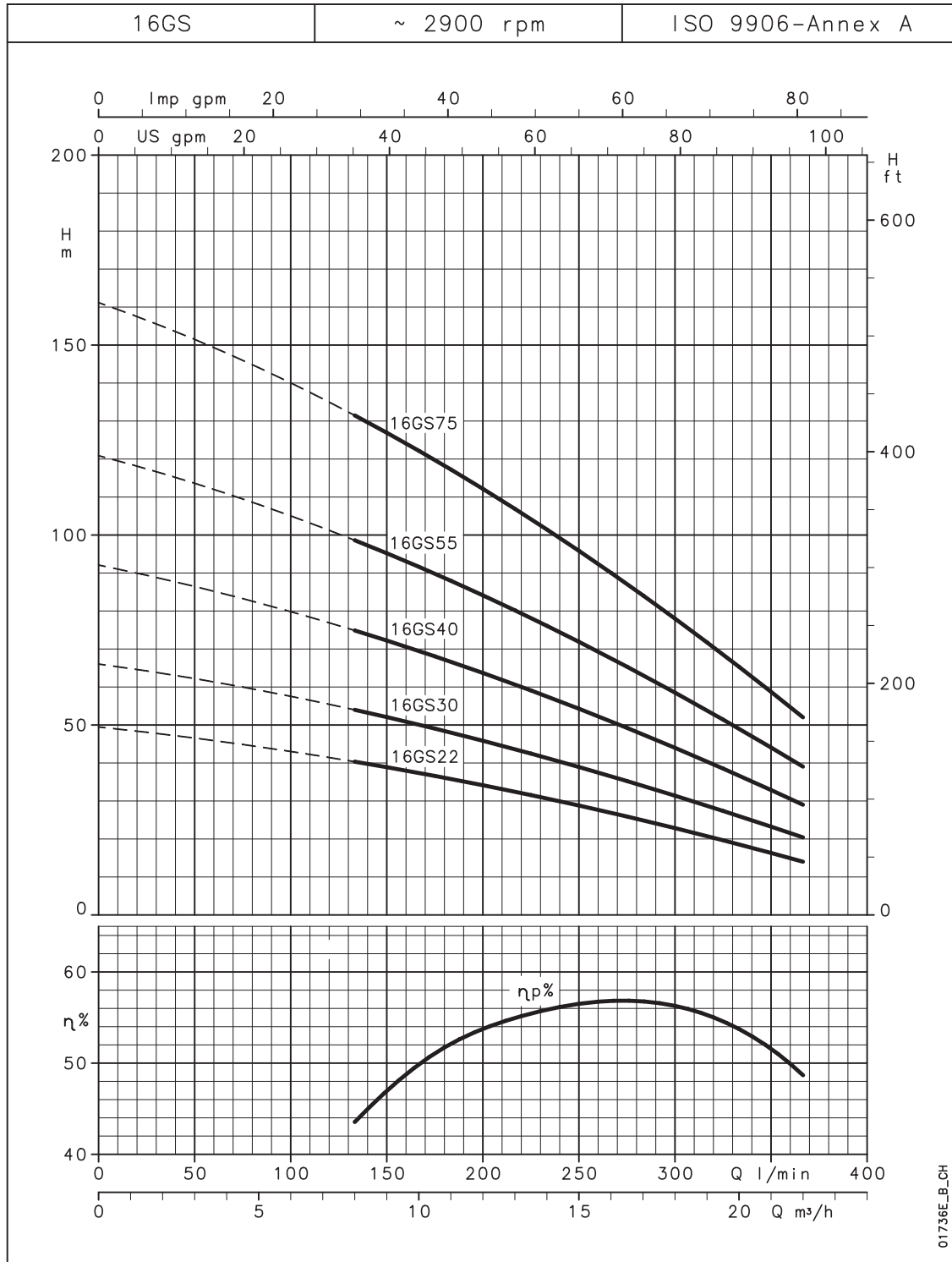

These performances are valid for liquids with density $\rho = 1.0 \text{ kg/dm}^3$ and kinematic viscosity $\nu = 1 \text{ mm}^2/\text{s}$.

Engineered for life



COOLING SHROUDS

01890_B_DD

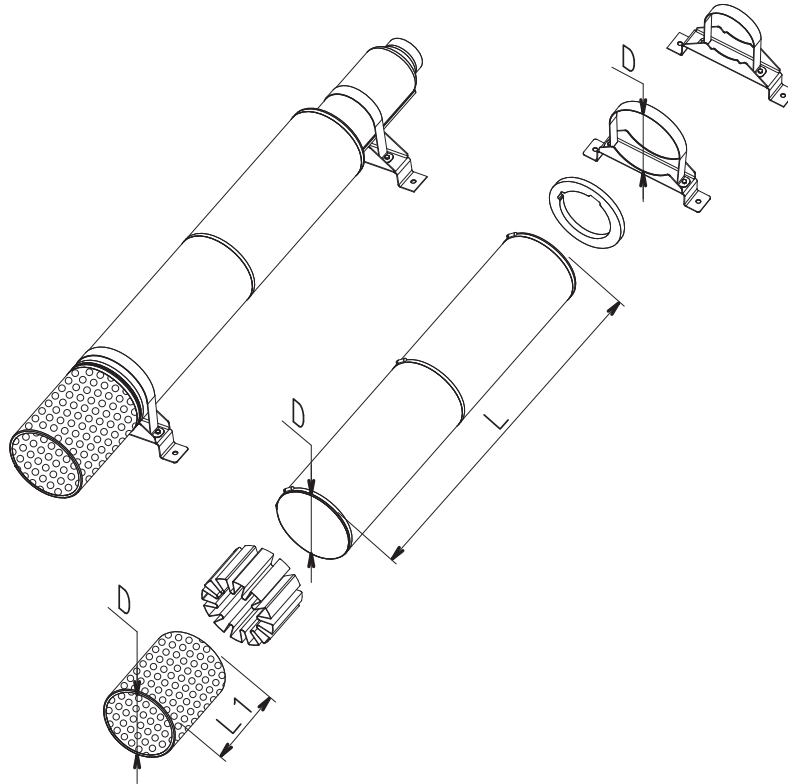

GS SERIES PUMP AND 4" MOTOR SELECTION TABLE

PUMP TYPE	MOTOR TYPE		COOLING SET SHROUD (D x L)	COOLING SET FILTER (D x L1)	COOLING SET BRACKETS (D)
	40S/B	L4C			
1GSL 2GS 4GS 6GS 8GS 12GS	0,37	0,37	D115X500	D115X117	D115/2 - 2PZ
	0,55	0,55			
	0,75	0,75			
	1,1	1,1	D115X800	D115X117	D115 - 2PZ
	1,5	1,5			
	2,2	2,2			
	3	3			
	4	4			
5,5	5,5	D115X1000	D115X117	D115 - 2PZ	
7,5	7,5				
16GS	2,2	2,2	D145X800	D145X158	D145 - 2PZ
	3	3			
	4	4	D145X1000	D145X158	D145 - 2PZ
	5,5	5,5			
	7,5	7,5			

gs_kit-raf50-en_b_ta

Engineered for life