

**THREADED
HORIZONTAL
MULTISTAGE
CENTRIFUGAL
ELECTRIC
PUMPS**

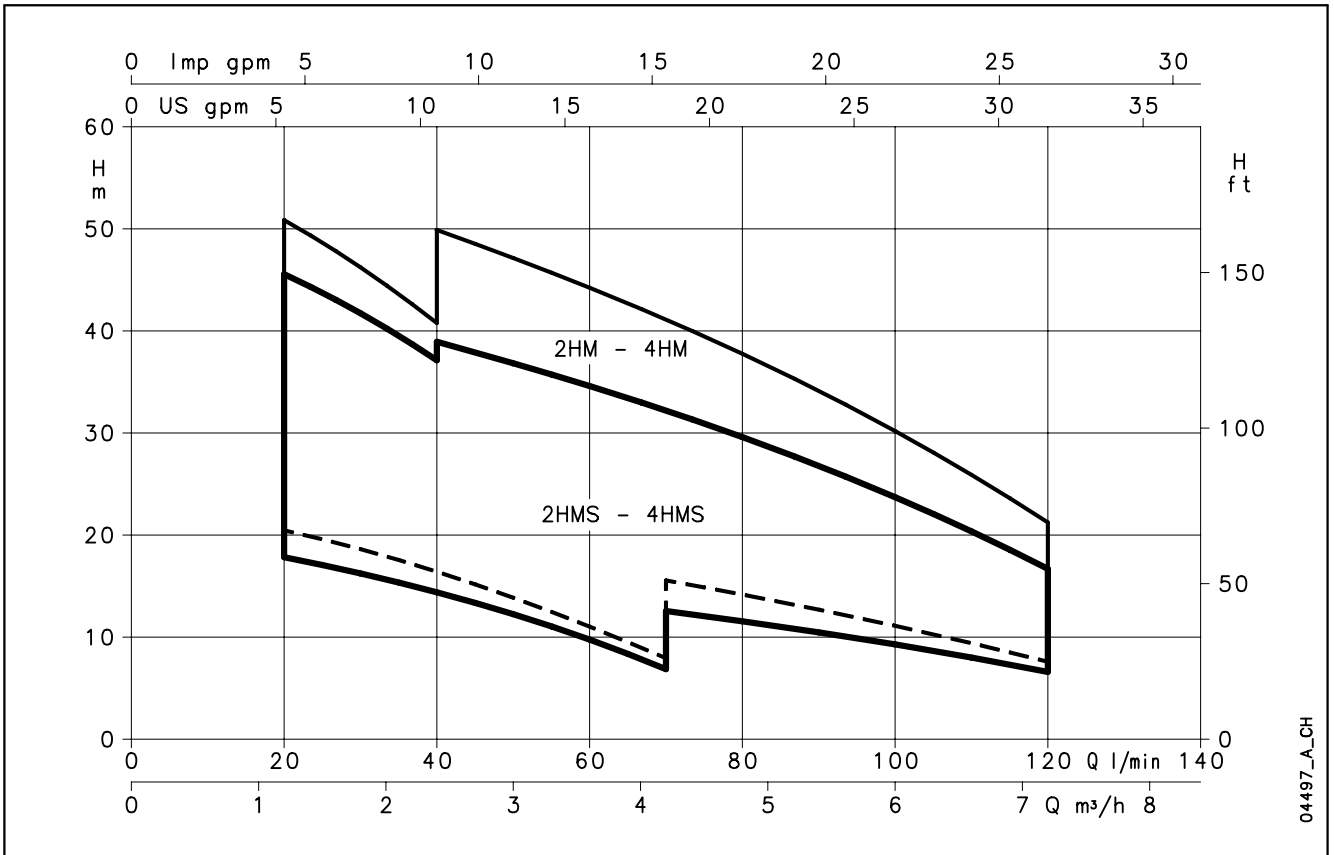

**2HM - 4HM
2HMS - 4HMS SERIES**



EDITION 08-2003

04497_A_CH

Lowara

Threaded horizontal multistage centrifugal electric pumps

2HM-4HM 2HMS-4HMS Series



MARKET SECTORS

INDUSTRIAL, CIVIL, AGRICULTURAL.

APPLICATIONS

- Pumping of water for domestic (HM) and industrial use (HMS).
- Small irrigation systems. The HMS series pump can handle water (containing additives) having moderate chemical aggressiveness, but free of suspended solids.
- Composition of pressure booster units for various purposes.
- Pumping of liquids compatible with AISI 316L stainless steel (DIN 1.4404) for HMS version.

SPECIFICATIONS

- **Delivery:**
2HM-4HM: up to 120 l/min (7.2 m³/h).
2HMS-4HMS: up to 120 l/min (7.2 m³/h).
- **Head:**
2HM-4HM: up to 60.7 meters.
2HMS-4HMS: up to 51.2 meters.
- Maximum operating pressure: 8 bar (PN8).
- Continuous duty.
- **Temperature** of pumped liquid:
-10°C to +60°C for HM.
-10°C to +110°C for HMS.
- Enclosed motor with external ventilation and finned casing made of aluminum alloy.
- Single-phase version with 220-240 V 50 Hz power supply, permanent capacitor and built-in, automatic reset overload protection. Three-phase version with 220-240/380-415 V 50 Hz power supply, overload protection to be provided by user.
- **Power:**
2HM-4HM: up to 0.9 kW.
2HMS-4HMS: up to 0.75 kW.
- Class F insulation.
- IP55 protection.

LIQUID END MADE ENTIRELY OF STAINLESS STEEL FOR HMS

SILENT OPERATION

HIGH PERFORMANCE AND RELIABILITY

MATERIALS

2HM-4HM SERIES

PART	MATERIAL			
		UNI	ASTM - AISI	EN - DIN
Pump body	Stainless steel	X5 CrNi 18-10	304	1.4301
Seal housing disk	Stainless steel	X5 CrNi 18-10	304	1.4301
Diffusers	Stainless steel	X5 CrNi 18-10	304	1.4301
First stage case	Stainless steel	X5 CrNi 18-10	304	1.4301
Spacers	Stainless steel	X5 CrNi 18-10	304	1.4301
Impellers	Technopolymer suitable for drinking water			
Shaft extension	Stainless steel	X5 CrNiMo 17-12-2	316	1.4401
Impeller lockscrew and washer	Stainless steel	X5 CrNi 18-10	304	1.4301
Fill/drain plugs	Nickel-plated brass			
Fill/drain plug gaskets	EPDM			
Mechanical seal	Ceramic/Carbon/ EPDM			
Seal shoulder washer	Stainless steel	X5 CrNi 18-10	304	1.4301
O-rings	EPDM			
Pump/motor support	Aluminium			
Pump body fastening screws	Zinc plated steel			

2HMS-4HMS SERIES

PART	MATERIAL			
		UNI	ASTM - AISI	EN - DIN
Pump body	Stainless steel	X2 CrNiMo 17-12-2	316L	1.4404
Seal housing disk	Stainless steel	X2 CrNiMo 17-12-2	316L	1.4404
Diffusers	Stainless steel	X2 CrNiMo 17-12-2	316L	1.4404
First stage case	Stainless steel	X2 CrNiMo 17-12-2	316L	1.4404
Spacers	Stainless steel	X2 CrNiMo 17-12-2	316L	1.4404
Impellers	Stainless steel	X2 CrNiMo 17-12-2	316L	1.4404
Shaft extension	Stainless steel	X5 CrNiMo 17-12-2	316	1.4401
Impeller lockscrew and washer	Stainless steel	X5 CrNiMo 17-12-2	316	1.4401
Fill/drain plugs	Stainless steel	X5 CrNiMo 17-12-2	316	1.4401
Fill/drain plug gaskets	EPDM			
Mechanical seal	Ceramic/Carbon/ EPDM			
Seal shoulder washer	Stainless steel	X5 CrNiMo 17-12-2	316	1.4401
O-rings	EPDM			
Pump/motor support	Aluminium			
Pump body fastening screws	Zinc plated steel			

HM - HMS MECHANICAL SEAL

The standard configuration has the characteristics shown in fig. 1 and table 1.

STANDARD MATERIALS (TABLE 1)

POS.	COMPONENT	MATERIAL
1	Spring	AISI 316 stainless steel
2	Shaft gasket	EPDM
3	Armature	AISI 316 stainless steel
4	Rotating assembly gasket	EPDM
5	Rotating assembly seal ring	Ceramic
6	Fixed assembly ring	Carbon
7	Fixed assembly gasket	EPDM

Various alternative materials are available on request.

The special configuration has the characteristics shown in fig. 1 and table 2.

A fixed-seal design with an anti-rotation lockpin is available on request.

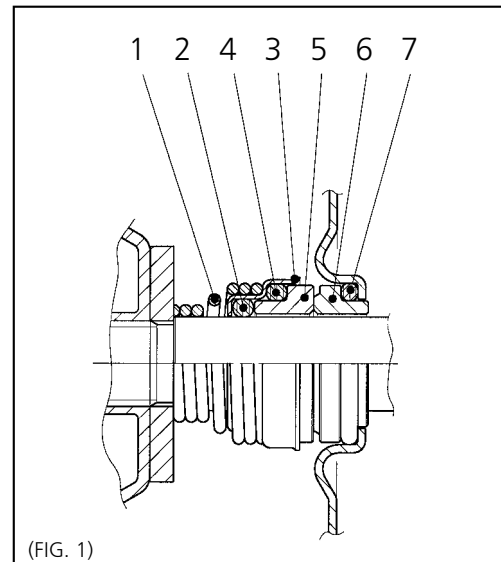

ALTERNATIVE MATERIALS (TABLE 2) (on request)

To determine the code of the electric pump with mechanical seal and O-rings made of alternative materials, the extension shown in the table must be added to the standard code.

EXTENSION CODE	POS. 1-2-3-4-7	MATERIAL 5 - 6
XAA	FPM	Ceramic - Special carbon
		Silicon carbide - Special carbon
		Silicon carbide - Tungsten carbide
		Tungsten carbide - Tungsten carbide*
XAA	FPM	Ceramic - Carbon
		Ceramic - Special carbon
		Silicon carbide - Special carbon
		Silicon carbide - Silicon carbide
		Silicon carbide - Tungsten carbide
		Tungsten carbide - Tungsten carbide*

* A version with anti-rotation lockpin is available on request.

ELECTRICAL DATA (50 HZ, 2850 RPM)

HM SERIES

PUMP TYPE	ABSORBED POWER*	ABSORBED CURRENT*	CAPACITOR
SINGLE-PHASE	kW	220-240 V A	μF / 450 V
2HM3	0.51	2.34	10
2HM4	0.66	2.92	14
2HM5	0.85	3.72	16
2HM7	1.13	5.09	20
4HM4	0.62	2.77	14
4HM5	0.86	3.76	16
4HM7	1.29	5.74	25
4HM9	2.45	6.49	25

PUMP TYPE	ABSORBED POWER*	ABSORBED CURRENT*	ABSORBED CURRENT*
THREE-PHASE	kW	220-240 V A	380-415 V A
2HM3T	0.47	1.80	1.04
2HM4T	0.67	2.56	1.48
2HM5T	0.87	2.94	1.70
2HM7T	1.12	3.74	2.16
4HM4T	0.62	2.51	1.45
4HM5T	0.88	2.96	1.71
4HM7T	1.21	4.33	2.50
4HM9T	1.38	4.61	2.66

* Maximum values within the operating range

hm-2p50_a_te

ELECTRICAL DATA (50 HZ, 2850 RPM)

HMS SERIES

PUMP TYPE	ABSORBED POWER*	ABSORBED CURRENT*	CAPACITOR
SINGLE-PHASE	kW	220-240 V A	μF / 450 V
2HMS3	0.47	2.25	10
2HMS4R	0.61	2.75	14
2HMS4	0.73	3.28	16
2HMS7	1.00	4.61	20
4HMS3	0.51	2.35	10
4HMS4	0.68	2.99	14
4HMS5	0.81	3.54	16
4HMS7	1.13	5.08	20

PUMP TYPE	ABSORBED POWER*	ABSORBED CURRENT*	ABSORBED CURRENT*
THREE-PHASE	kW	220-240 V A	380-415 V A
2HMS3T	0.42	1.77	1.02
2HMS4RT	0.61	2.51	1.45
2HMS4T	0.73	2.79	1.61
2HMS7T	0.98	3.53	2.04
4HMS3T	0.48	1.8	1.04
4HMS4T	0.69	2.58	1.49
4HMS5T	0.82	2.89	1.67
4HMS7T	1.10	3.65	2.11

*Maximum values within the operating range

hms-2p50_a_te

HYDRAULIC PERFORMANCE TABLE, HM SERIES

PUMP TYPE	MOTOR POWER*		Q = DELIVERY										
			l/min	0	20	30	40	50	60	70	80	100	120
			m ³ /h	0	1.2	1.8	2.4	3	3.6	4.2	4.8	6	7.2
kW		HP	H = TOTAL HEAD METERS COLUMN OF WATER										
2HM3(T)	0.3	0.4	23.8	21.4	19.7	17.6	15.2	12.5	9.4				
2HM4(T)	0.45	0.6	35.4	32.0	29.5	26.5	23.0	19.0	14.5				
2HM5(T)	0.55	0.75	46.8	42.1	38.8	34.9	30.4	25.3	19.6				
2HM7(T)	0.75	1	58.5	53.2	49.5	44.9	39.5	33.2	25.8				
4HM4(T)	0.45	0.6	24.6			20.3	19.1	17.8	16.5	15.0	11.9	8.3	
4HM5(T)	0.55	0.75	35.4			28.9	27.2	25.4	23.6	21.6	17.2	12.1	
4HM7(T)	0.75	1	48.1			40.2	38.2	36.0	33.7	31.2	25.2	17.7	
4HM9(T)	0.9	1.2	60.7			51.2	48.6	45.9	42.9	39.7	32.4	23.6	

hm-2p50_a_th

HYDRAULIC PERFORMANCE TABLE, HMS SERIES

PUMP TYPE	MOTOR POWER*		Q = DELIVERY										
			l/min	0	20	30	40	50	60	70	80	100	120
			m ³ /h	0	1.2	1.8	2.4	3	3.6	4.2	4.8	6	7.2
kW		HP	H = TOTAL HEAD METERS COLUMN OF WATER										
2HMS3(T)	0.3	0.4	20.5	17.8	16.2	14.4	12.3	9.8	6.9				
2HMS4R(T)	0.45	0.6	30.2	26.7	24.3	21.4	18.1	14.4	10.3				
2HMS4(T)	0.45	0.6	41.1	35.6	32.4	28.7	24.6	19.8	14.4				
2HMS7(T)	0.75	1	51.2	45.6	41.7	37.1	31.7	25.4	18.2				
4HMS3(T)	0.3	0.4	19.1			15.3	14.4	13.5	12.6	11.6	9.3	6.6	
4HMS4(T)	0.45	0.6	27.8			22.8	21.5	20.1	18.6	17.0	13.5	9.5	
4HMS5(T)	0.55	0.75	37.2			30.6	28.9	27.0	25.1	23.0	18.2	12.7	
4HMS7(T)	0.75	1	46.7			38.9	36.8	34.6	32.2	29.6	23.7	16.7	

hms-2p50_a_th

ELECTRIC PUMP IDENTIFICATION CODE

The HM-HMS series models are identified as follows:

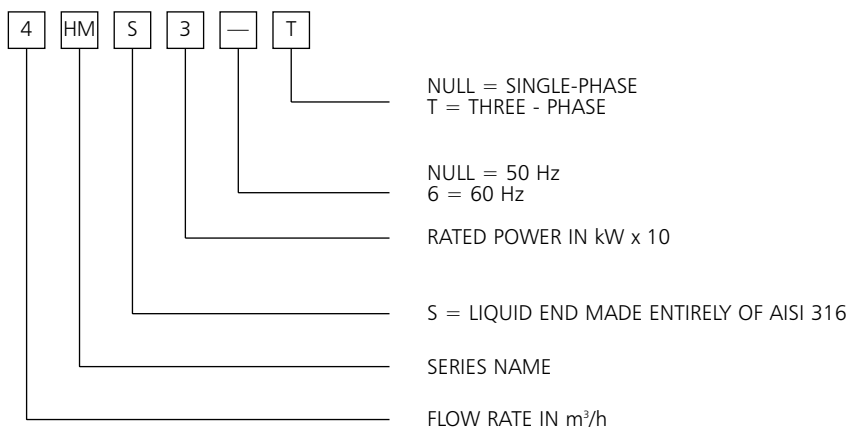

**2HM SERIES
OPERATING CHARACTERISTICS AT 2850 rpm 50 Hz**

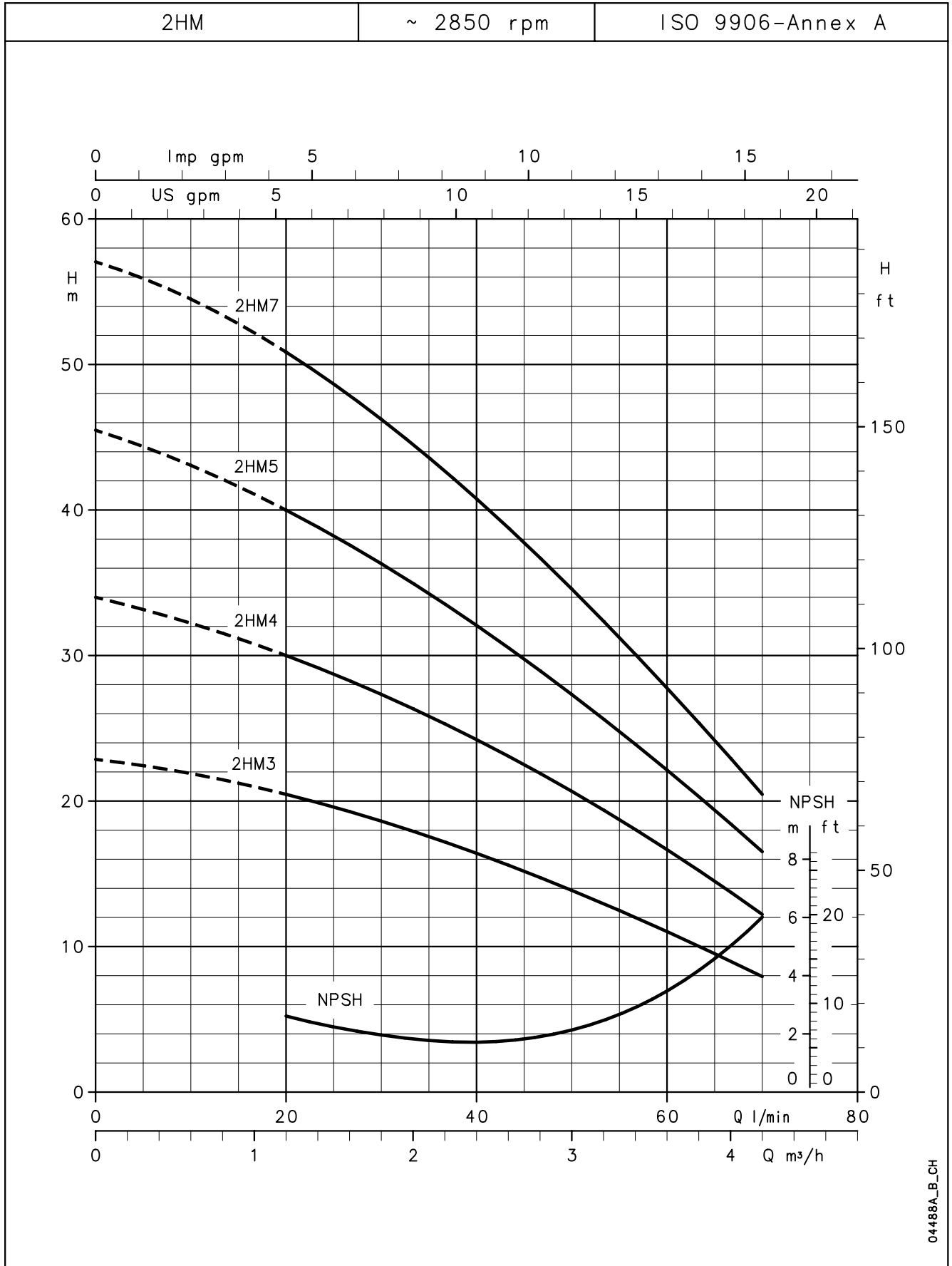

The performances are valid for liquids with density $\rho = 1.0 \text{ kg/dm}^3$ and kinematic viscosity $\nu = 1 \text{ mm}^2/\text{sec}$.

**4HM SERIES
OPERATING CHARACTERISTICS AT 2850 rpm 50 Hz**

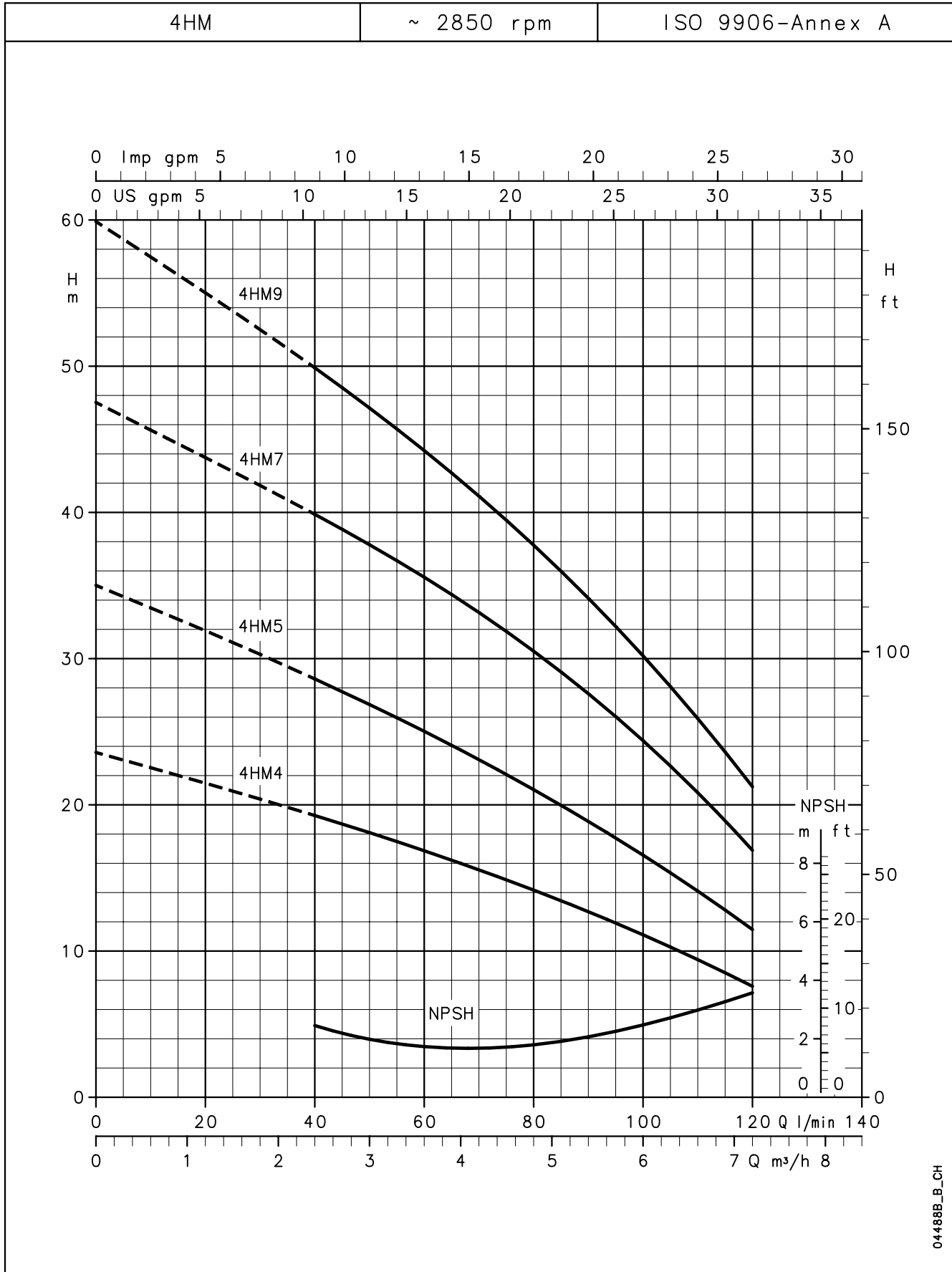

044888_B_CH

The performances are valid for liquids with density $\leq 1.0 \text{ kg/dm}^3$ and kinematic viscosity $\leq 1 \text{ mm}^2/\text{sec}$.

**2HMS SERIES
OPERATING CHARACTERISTICS AT 2850 rpm 50 Hz**

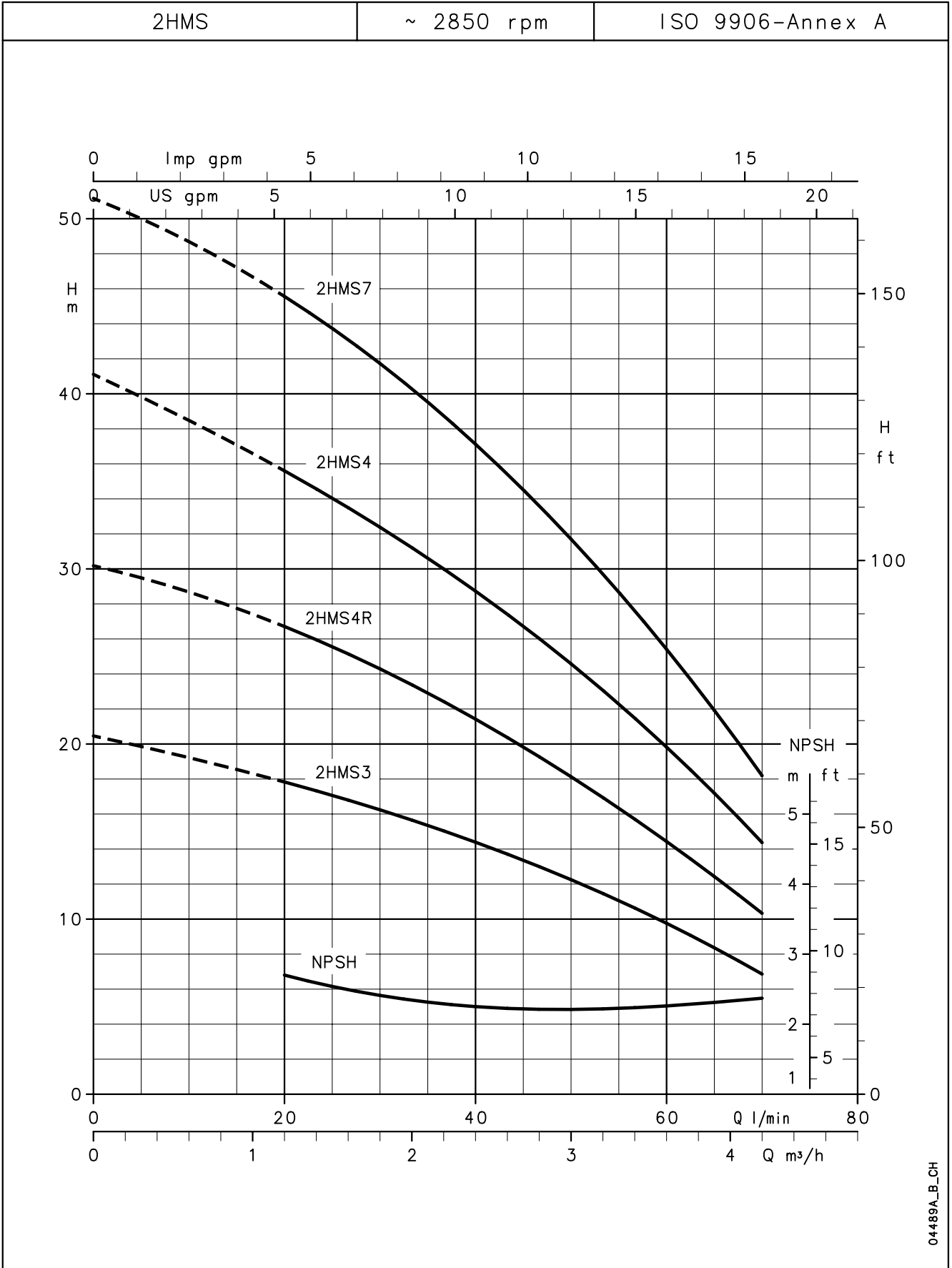

04489A_B_CH

The performances are valid for liquids with density $\rho = 1.0 \text{ kg/dm}^3$ and kinematic viscosity $\nu = 1 \text{ mm}^2/\text{sec}$.

**4HMS SERIES
OPERATING CHARACTERISTICS AT 2850 rpm 50 Hz**

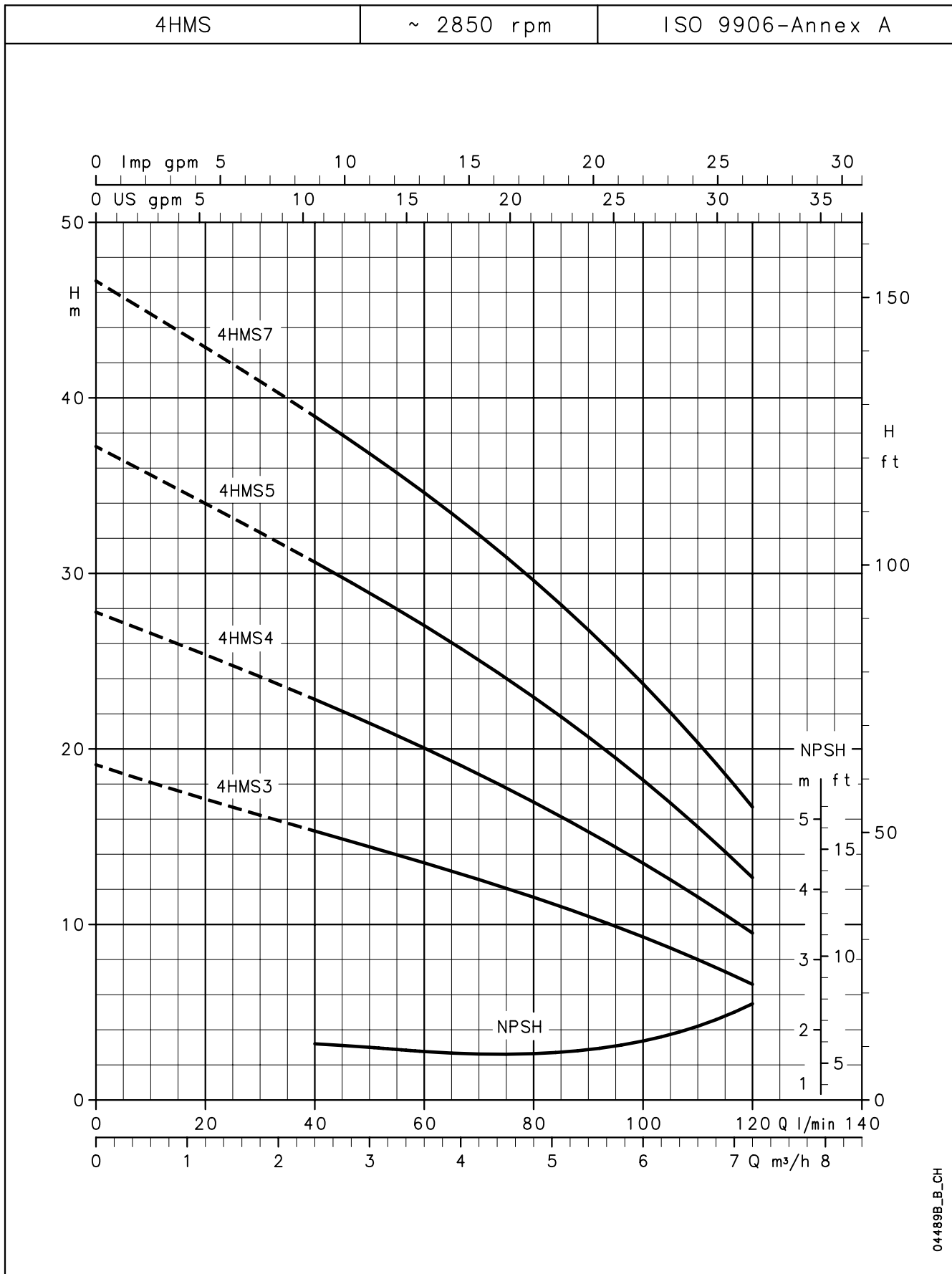

The performances are valid for liquids with density $\leq 1.0 \text{ kg/dm}^3$ and kinematic viscosity $\leq 1 \text{ mm}^2/\text{sec}$.

DIMENSIONS AND WEIGHTS, HM-HMS SERIES

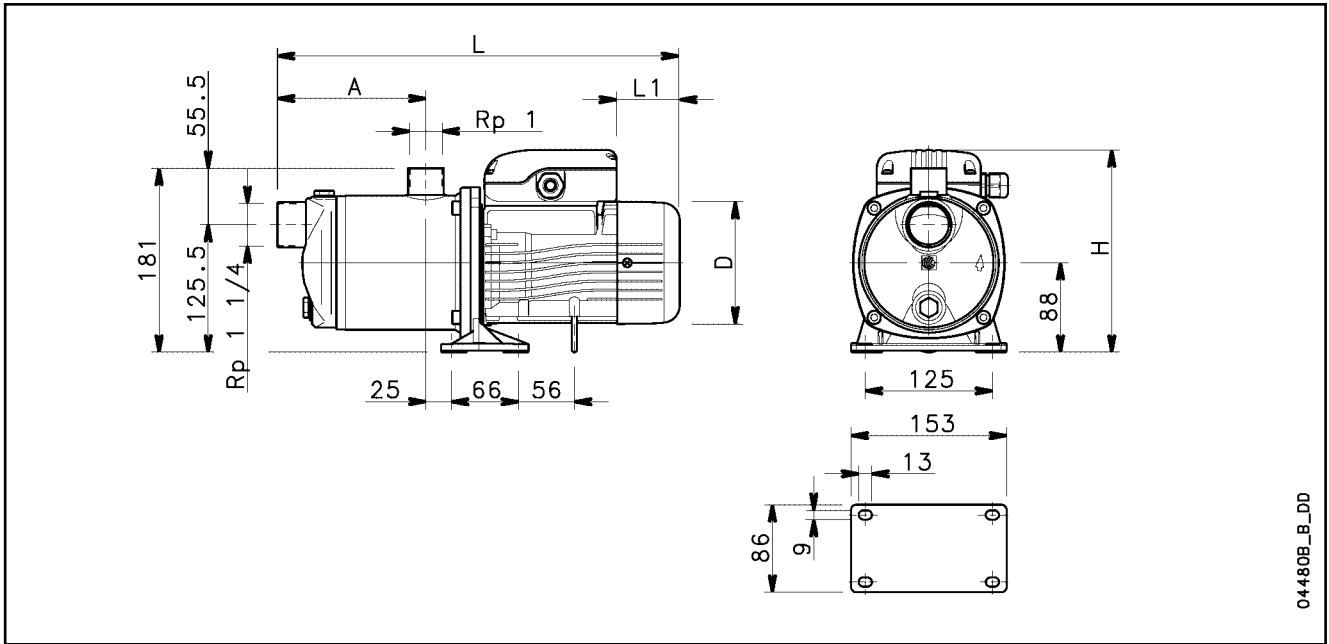

PUMP TYPE	DIMENSIONS (mm)						WEIGHT kg
	NUMBER OF STAGES	A	D	L	L1	H	
2HM3	2	96	120	345	62	199	7
2HM4	3	121	120	370	62	199	8.1
2HM5	4	146	120	395	62	199	8.9
2HM7	5	171	140	434	76	209	11.7
4HM4	2	96	120	345	62	199	8.7
4HM5	3	121	120	370	62	199	8.5
4HM7	4	146	140	409	31	218	11.3
4HM9	5	171	140	434	31	218	12.4
2HM3T	2	96	120	345	62	199	7.1
2HM4T	3	121	120	370	62	199	7.9
2HM5T	4	146	120	395	62	199	8.9
2HM7T	5	171	140	434	76	209	11.7
4HM4T	2	96	120	345	62	199	7.6
4HM5T	3	121	120	370	62	199	8.4
4HM7T	4	146	140	409	76	209	11.7
4HM9T	5	171	140	434	76	209	12.2
2HMS3	2	96	120	345	62	199	7.3
2HMS4R	3	121	120	370	62	199	8.4
2HMS4	4	146	120	395	62	199	9.3
2HMS7	5	171	140	434	76	209	12
4HMS3	2	96	120	345	62	199	7.4
4HMS4	3	121	120	370	62	199	8.4
4HMS5	4	146	120	395	62	199	9.2
4HMS7	5	171	140	434	76	209	12
2HMS3T	2	96	120	345	62	199	7.2
2HMS4RT	3	121	120	370	62	199	8.3
2HMS4T	4	146	120	395	62	199	9
2HMS7T	5	171	140	434	76	209	11.7
4HMS3T	2	96	120	345	62	199	7.2
4HMS4T	3	121	120	370	62	199	8.5
4HMS5T	4	146	120	395	62	199	9.2
4HMS7T	5	171	140	434	76	209	12

hm-hms-2p50_a_td

**LIST OF MAIN COMPONENTS
HM-HMS SERIES**

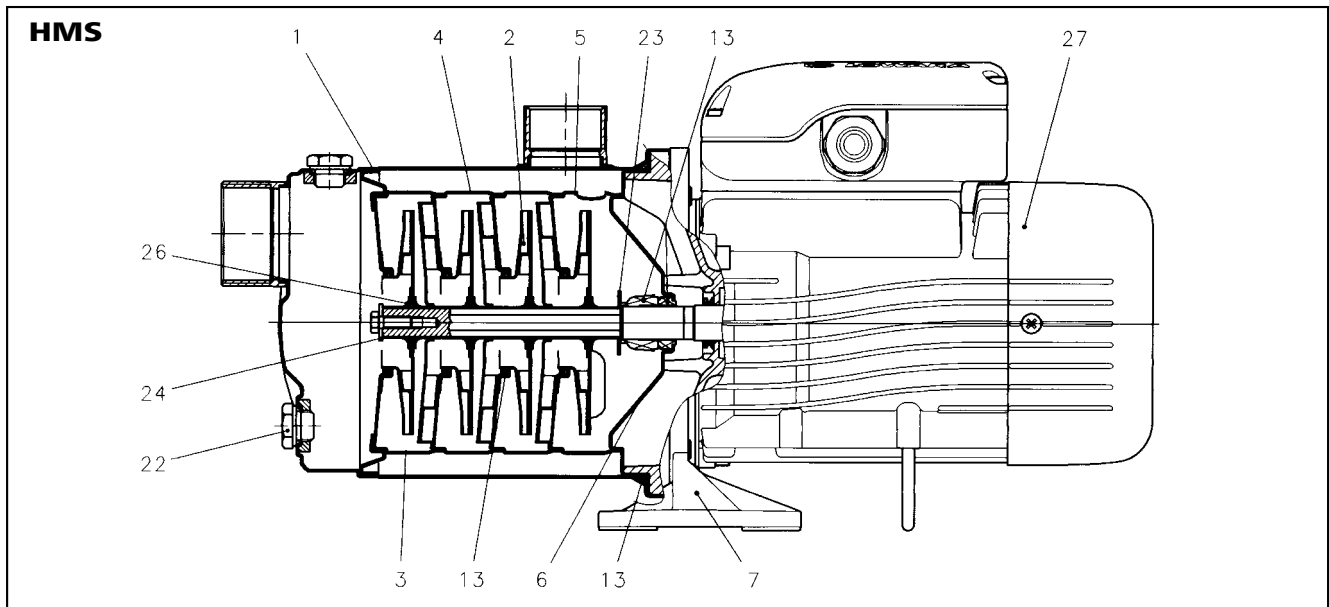
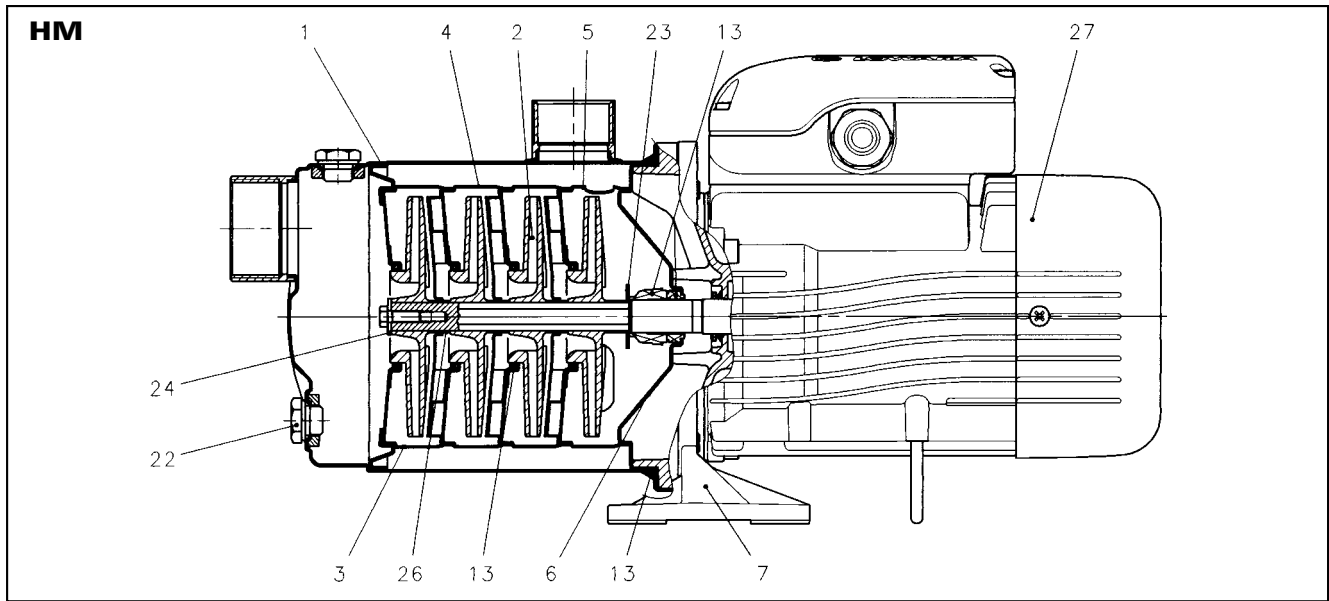

N. RIF.	DESCRIPTION	
1	Pump body	
* 2	Impeller	
3	First stage case	
	Diffuser	
5	Final diffuser	
6	Seal housing disk	
7	Motor/pump support	
* 13	Mechanical seal kit + O-ring	
22	Fill/drain plug	O-ring
23	Seal shoulder washer	
24	Impeller lock washer	
26	Impeller spacer	
27	Motor	

* Recommended spare parts

TECHNICAL APPENDIX

HM-HMS SERIES
**STANDARD CONFIGURATION: MECHANICAL SEAL
CARBON/CERAMIC O-RINGS NBR**

TABLE OF COMPATIBILITY FOR LIQUIDS MOST USED

 For other liquids refer to our web page www.lowara.com

LIQUID	CONCENTRATION %	TEMPERATURE -MIN (°C) -MAX (°C)	DENSITY kg/dm ³	WET PART		MECHANICAL SEAL HM - HMS		O-RINGS	
				HM (2) (AISI 304+Noryl)	HMS (AISI 316)	NUMBER B	NUMBER A	EPDM	FPM
Acetic acid (1) CH ₃ -CO-OH configuration code	80	-10 +70	1.05	standard product	standard product	2	3	1	3
Citric acid + water H ₈ C ₆ O ₇ H ₂ O configuration code	5	-10 +70	1.54	standard product	standard product	1	1	1	1
Hydrochloric acid (1) H Cl configuration code	2	-5 +25	1.20	not recommended	2 ...XAA	3	2	3	1
Water H ₂ O configuration code	100	-5 +90	1.00	standard product	standard product	1	1	1	1
Water deionized configuration code	100	0 +110		standard product	standard product	1	1	1	1
Water demineralized configuration code	100	-25 +110		standard product	standard product	1	1	1	1
Sea water (4) configuration code	/	-10 +25		3 not recommended	2 standard product	2	2	1	1
Freon 112 C Cl ₂ F C Cl ₂ F configuration code	100	-20 +30	1.57	2 ...XAA	1 ...XAA	3	1	3	1
Freon 113 C Cl ₂ FC Cl F ₂ configuration code	100	-20 +30	1.42	2 ...XAA	1 ...XAA	3	2	3	2
Ethylene glycol OH (C ₂ H ₄ O) ₃ H configuration code	50	-20 +60	1.13	1 standard product	1 standard product	2	2	1	1
Kerosene configuration code	100	0 +80		3 not recommended	1 standard product	3	2	3	1
Castor oil configuration code	100	-10 +110		2 ...XAA	1 ...XAA	2	1	2	1
Mineral oil configuration code	100	-5 +110	0.94	2 ...XAA	1 ...XAA	3	1	3	1
Perchloroethylene Cl ₂ C=CCl ₂ (Tetrachloroethylene) (1) configuration code	/	-10 +50	1.6	3 not recommended	1 ...XAA	3	1	3	1
Caustic Soda Na OH configuration code	25	0 +70	2.13	2 not recommended	1 ...XBB	2	3	1	2
Fruit juice configuration code	/	-5 +70		1 standard product	1 standard product	1	1	1	1

(X) - Positive suction head required

 1 = Good compatibility
 2 = Poor compatibility
 3 = No compatibility

(1) Dangerous liquid (toxic, poisonous, attacks skin, irritant, etc.).

(2) Flammable and explosive liquid.

(3) 4-poles versions only.

(4) The stainless steel compatibility depends on the chlorine content in relationship with the liquid temperature, a detailed analysis is necessary.

TYPICAL APPLICATIONS OF HM SERIES ELECTRIC PUMPS***Water Purification:***

Filtration
De-ionized water
Water treatment
Commercial and residential pools

Waste Management:

Waste treatment
Pollution control

Plastics

Temperature control
Extrusion machines
Manufacture of polymers
Heat treatment

Machine Tool

Degreasing
Parts washing
Chemical treatment

Agricultural/ residential applications: Graphics:

Irrigation
Greenhouses
Humidifiers
Water supply
Film washing
Cooling processes

Heating, Ventilating & Air Conditioning (HVAC)

Air scrubbers
Water re-circulation
Cooling towers
Cooling systems
Temperature control
Chillers
Induction heating
Heat exchangers
Water heating

Marine:

Water on board ships

Computers:

Washing of circuit boards
Unit cooling

Laundry:

Commercial washing

Food and Drink:

Food processing
Bottle washing
Citrus Processing
Dish washing
Brewing
Sanitary ware

General Industry:

Spray Booths
Light chemical transfer
Boster systems

Medical:

Laser cooling
Massages
Medical chillers
Sanitary equipment

NPSH

The minimum operating values that can be reached at the pump suction end are limited by the onset of cavitation.

Cavitation is the formation of vapour-filled cavities within liquids where the pressure is locally reduced to a critical value, or where the local pressure is equal to, or just below the vapour pressure of the liquid.

The vapour-filled cavities flow with the current and when they reach a higher pressure area the vapour contained in the cavities condenses. The cavities collide, generating pressure waves that are transmitted to the walls. These, being subjected to stress cycles, gradually become deformed and yield due to fatigue. This phenomenon, characterized by a metallic noise produced by the hammering on the pipe walls, is called incipient cavitation.

The damage caused by cavitation may be magnified by electrochemical corrosion and a local rise in temperature due to the plastic deformation of the walls. The materials that offer the highest resistance to heat and corrosion are alloy steels, especially austenitic steel. The conditions that trigger cavitation may be assessed by calculating the total net suction head, referred to in technical literature with the acronym NPSH (Net Positive Suction Head).

The NPSH represents the total energy (expressed in m.) of the liquid measured at suction under conditions of incipient cavitation, excluding the vapour pressure (expressed in m.) that the liquid has at the pump inlet.

To find the static height h_z at which to install the machine under safe conditions, the following formula must be verified:

$$h_p + h_z \geq (NPSH_r + 0.5) + h_f + h_{pv} \quad \text{①}$$

where:

- h_p** is the absolute pressure applied to the free liquid surface in the suction tank, expressed in m. of liquid; h_p is the quotient between the barometric pressure and the specific weight of the liquid.
- h_z** is the suction lift between the pump axis and the free liquid surface in the suction tank, expressed in m.; h_z is negative when the liquid level is lower than the pump axis.
- h_f** is the flow resistance in the suction line and its accessories, such as: fittings, foot valve, gate valve, elbows, etc.
- h_{pv}** is the vapour pressure of the liquid at the operating temperature, expressed in m. of liquid. h_{pv} is the quotient between the P_v vapour pressure and the liquid's specific weight.
- 0.5** is the safety factor.

The maximum possible suction head for installation depends on the value of the atmospheric pressure (i.e. the elevation above sea level at which the pump is installed) and the temperature of the liquid.

To help the user, with reference to water temperature (4°C) and to the elevation above sea level, the following tables show the drop in hydraulic pressure head in relation to the elevation above sea level, and the suction loss in relation to temperature.

Water temperature (°C)	20	40	60	80	90	110	120
Suction loss (m)	0,2	0,7	2,0	5,0	7,4	15,4	21,5

Elevation above sea level (m)	500	1000	1500	2000	2500	3000
Suction loss (m)	0,55	1,1	1,65	2,2	2,75	3,3

Flow resistance is shown in the tables at pages 19-20 of this catalogue. To reduce it to a minimum, especially in cases of high suction head (over 4-5 m.) or within the operating limits with high flow rates, we recommend using a suction line having a larger diameter than that of the pump's suction port. It is always a good idea to position the pump as close as possible to the liquid to be pumped.

Make the following calculation:

Liquid: water at 15°C $\rho = 1 \text{ kg/dm}^3$
 Flow rate required: 30 m³/h
 Head for required delivery: 43 m.
 Suction lift: 3.5 m.
 The selection is an FHE 40-200/75 pump whose NPSH required value is, at 30 m³/h, 2.5 m.

For water at 15°C the h_{pv} term is $\frac{P_v}{\rho \cdot g} = 0,174 \text{ m (0.01701 bar)}$

and $h = \frac{P_a}{\rho \cdot g} = 10,33 \text{ m}$

The H_f flow resistance in the suction line with foot valves is 1.2 m.

By substituting the parameters in formula ① with the numeric values above, we have:

$$10,33 + (-3,5) \geq (2,5 + 0,5) + 1,2 + 0,17$$

from which we have: 6.8 > 4.4

The relation is therefore verified.

VAPOUR PRESSURE
ps VAPOUR PRESSURE AND ← DENSITY OF WATER TABLE

t °C	T K	ps bar	ρ kg/dm ³
0	273,15	0,00611	0,9998
1	274,15	0,00657	0,9999
2	275,15	0,00706	0,9999
3	276,15	0,00758	0,9999
4	277,15	0,00813	1,0000
5	278,15	0,00872	1,0000
6	279,15	0,00935	1,0000
7	280,15	0,01001	0,9999
8	281,15	0,01072	0,9999
9	282,15	0,01147	0,9998
10	283,15	0,01227	0,9997
11	284,15	0,01312	0,9997
12	285,15	0,01401	0,9996
13	286,15	0,01497	0,9994
14	287,15	0,01597	0,9993
15	288,15	0,01704	0,9992
16	289,15	0,01817	0,9990
17	290,15	0,01936	0,9988
18	291,15	0,02062	0,9987
19	292,15	0,02196	0,9985
20	293,15	0,02337	0,9983
21	294,15	0,2485	0,9981
22	295,15	0,02642	0,9978
23	296,15	0,02808	0,9976
24	297,15	0,02982	0,9974
25	298,15	0,03166	0,9971
26	299,15	0,03360	0,9968
27	300,15	0,03564	0,9966
28	301,15	0,03778	0,9963
29	302,15	0,04004	0,9960
30	303,15	0,04241	0,9957
31	304,15	0,04491	0,9954
32	305,15	0,04753	0,9951
33	306,15	0,05029	0,9947
34	307,15	0,05318	0,9944
35	308,15	0,05622	0,9940
36	309,15	0,05940	0,9937
37	310,15	0,06274	0,9933
38	311,15	0,06624	0,9930
39	312,15	0,06991	0,9927
40	313,15	0,07375	0,9923
41	314,15	0,07777	0,9919
42	315,15	0,08198	0,9915
43	316,15	0,09639	0,9911
44	317,15	0,09100	0,9907
45	318,15	0,09582	0,9902
46	319,15	0,10086	0,9898
47	320,15	0,10612	0,9894
48	321,15	0,11162	0,9889
49	322,15	0,11736	0,9884
50	323,15	0,12335	0,9880
51	324,15	0,12961	0,9876
52	325,15	0,13613	0,9871
53	326,15	0,14293	0,9862
54	327,15	0,15002	0,9862
55	328,15	0,15741	0,9857

t °C	T K	ps bar	ρ kg/dm ³
56	329,15	0,16511	0,9852
57	330,15	0,17313	0,9846
58	331,15	0,18147	0,9842
59	332,15	0,19016	0,9837
60	333,15	0,19920	0,9232
61	334,15	0,2086	0,9826
62	335,15	0,2184	0,9821
63	336,15	0,2286	0,9816
64	337,15	0,2391	0,9811
65	338,15	0,2501	0,9805
66	339,15	0,2615	0,9799
67	340,15	0,2733	0,9793
68	341,15	0,2856	0,9788
69	342,15	0,2984	0,9782
70	343,15	0,3116	0,9777
71	344,15	0,3253	0,9770
72	345,15	0,3396	0,9765
73	346,15	0,3543	0,9760
74	347,15	0,3696	0,9753
75	348,15	0,3855	0,9748
76	349,15	0,4019	0,9741
77	350,15	0,4189	0,9735
78	351,15	0,4365	0,9729
79	352,15	0,4547	0,9723
80	353,15	0,4736	0,9716
81	354,15	0,4931	0,9710
82	355,15	0,5133	0,9704
83	356,15	0,5342	0,9697
84	357,15	0,5557	0,9691
85	358,15	0,5780	0,9684
86	359,15	0,6011	0,9678
87	360,15	0,6249	0,9671
88	361,15	0,6495	0,9665
89	362,15	0,6749	0,9658
90	363,15	0,7011	0,9652
91	364,15	0,7281	0,9644
92	365,15	0,7561	0,9638
93	366,15	0,7849	0,9630
94	367,15	0,8146	0,9624
95	368,15	0,8453	0,9616
96	369,15	0,8769	0,9610
97	370,15	0,9094	0,9602
98	371,15	0,9430	0,9596
99	372,15	0,9776	0,9586
100	373,15	1,0133	0,9581
102	375,15	1,0878	0,9567
104	377,15	1,1668	0,9552
106	379,15	1,2504	0,9537
108	381,15	1,3390	0,9522
110	383,15	1,4327	0,9507
112	385,15	1,5316	0,9491
114	387,15	1,6362	0,9476
116	389,15	1,7465	0,9460
118	391,15	1,8628	0,9445
120	393,15	1,9854	0,9429

t °C	T K	ps bar	ρ kg/dm ³
122	395,15	2,1145	0,9412
124	397,15	2,2504	0,9396
126	399,15	2,3933	0,9379
128	401,15	2,5435	0,9362
130	403,15	2,7013	0,9346
132	405,15	2,8670	0,9328
134	407,15	3,041	0,9311
136	409,15	3,223	0,9294
138	411,15	3,414	0,9276
140	413,15	3,614	0,9258
145	418,15	4,155	0,9214
150	423,15	4,760	0,9168
155	428,15	5,433	0,9121
160	433,15	6,181	0,9073
165	438,15	7,008	0,9024
170	443,15	7,920	0,8973
175	448,15	8,924	0,8921
180	453,15	10,027	0,8869
185	458,15	11,233	0,8815
190	463,15	12,551	0,8760
195	468,15	13,987	0,8704
200	473,15	15,55	0,8647
205	478,15	17,243	0,8588
210	483,15	19,077	0,8528
215	488,15	21,060	0,8467
220	493,15	23,198	0,8403
225	498,15	25,501	0,8339
230	503,15	27,976	0,8273
235	508,15	30,632	0,8205
240	513,15	33,478	0,8136
245	518,15	36,523	0,8065
250	523,15	39,776	0,7992
255	528,15	43,246	0,7916
260	533,15	46,943	0,7839
265	538,15	50,877	0,7759
270	543,15	55,058	0,7678
275	548,15	59,496	0,7593
280	553,15	64,202	0,7505
285	558,15	69,186	0,7415
290	563,15	74,461	0,7321
295	568,15	80,037	0,7223
300	573,15	85,927	0,7122
305	578,15	92,144	0,7017
310	583,15	98,700	0,6906
315	588,15	105,61	0,6791
320	593,15	112,89	0,6669
325	598,15	120,56	0,6541
330	603,15	128,63	0,6404
340	613,15	146,05	0,6102
350	623,15	165,35	0,5743
360	633,15	186,75	0,5275
370	643,15	210,54	0,4518
374,15	647,30	221,2	0,3154

FLOW RESISTANCE
TABLE OF FLOW RESISTANCE IN 100 M OF A NEW AND STRAIGHT CAST IRON PIPELINE

FLOW RATE		NOMINAL DIAMETER IN mm AND INCHES																		
m ³ /h	l/min.	15 1/2"	20 3/4"	25 1"	32 1 1/4"	40 1 1/2"	50 2"	65 2 1/2"	80 3"	100 4"	125 5"	150 6"	175 7"	200 8"	250 10"	300 12"	350 14"	400 16"		
0,6	10	V	0,94	0,53	0,34	0,21														
		hr	11,8	2,82	1	0,25														
0,9	15	V	1,42	0,8	0,51	0,31														
		hr	25,1	6,04	2,16	0,55														
1,2	20	V	1,89	1,06	0,68	0,41	0,27													
		hr	43,1	10,4	3,72	0,95	0,31													
1,5	25	V	2,36	1,33	0,85	0,52	0,33													
		hr	64,5	15,8	5,68	1,47	0,47													
1,8	30	V	2,83	1,59	1,02	0,62	0,4													
		hr	92	22,3	8	2,09	0,66													
2,1	35	V	3,3	1,86	1,19	0,73	0,46	0,3												
		hr	123	29,8	10,8	2,81	0,89	0,31												
2,4	40	V	3,77	2,12	1,36	0,83	0,53	0,34												
		hr	164	38,2	13,8	2,65	1,15	0,4												
3	50	V	4,72	2,65	1,7	1,04	0,66	0,42												
		hr	246	58,2	21,5	5,6	1,75	0,61												
3,6	60	V	3,18	2,04	1,24	0,8	0,51													
		hr	82	30	8	2,48	0,86													
4,2	70	V	3,72	2,38	1,45	0,93	0,59													
		hr	110	40	10,8	3,33	1,14													
4,8	80	V	4,25	2,72	1,66	1,06	0,68													
		hr	141	51,5	13,9	4,3	1,46													
5,4	90	V		3,06	1,87	1,19	0,76	0,45												
		hr		64	17,5	5,4	1,82	0,46												
6	100	V		3,4	2,07	1,33	0,85	0,5												
		hr		79	21,4	6,6	2,22	0,56												
7,5	125	V		4,25	2,59	1,66	1,06	0,63												
		hr		120	33	10	3,4	0,86												
9	150	V			3,11	1,99	1,27	0,75	0,5											
		hr			47	14,2	4,74	1,21	0,43											
10,5	175	V			3,63	2,32	1,49	0,88	0,58											
		hr			63	19	6,3	1,63	0,57											
12	200	V			4,15	2,65	1,7	1,01	0,66											
		hr			82	24,5	8,1	2,1	0,74											
15	250	V			5,18	3,32	2,12	1,26	0,83	0,53										
		hr			126	37,5	12,3	3,2	1,12	0,36										
18	300	V				3,98	2,55	1,51	1	0,64										
		hr				53	17,3	4,5	1,58	0,51										
24	400	V				5,31	3,4	2,01	1,33	0,85										
		hr				92	29,5	7,8	2,7	0,89										
30	500	V				6,63	4,25	2,51	1,66	1,06	0,68									
		hr				140	44,8	12	4,13	1,36	0,48									
36	600	V				5,1	3,02	1,99	1,27	0,82										
		hr				63	16,9	5,8	1,93	0,68										
42	700	V				5,94	3,52	2,32	1,49	0,95										
		hr				84	22,6	7,8	2,6	0,9										
48	800	V				6,79	4,02	2,65	1,70	1,09	0,75									
		hr				108	29	10	3,35	1,16	0,43									
54	900	V				7,64	4,52	2,99	1,91	1,22	0,85									
		hr				134	36	12,5	4,2	1,45	0,54									
60	1000	V					5,03	3,32	2,12	1,36	0,94									
		hr					44,5	15,2	5,14	1,76	0,66									
75	1250	V					6,28	4,15	2,65	1,70	1,18	0,87								
		hr					68	23	7,9	2,68	1	0,48								
90	1500	V					7,54	4,98	3,18	2,04	1,42	1,04								
		hr					96	32,6	11,2	3,77	1,42	0,68								
105	1750	V					8,79	5,81	3,72	2,38	1,65	1,21	0,93							
		hr					129	43,5	15	5,04	1,9	0,91	0,45							
120	2000	V						6,63	4,25	2,72	1,89	1,39	1,06	0,68						
		hr						56	19,4	6,5	2,43	1,18	0,58	0,16						
150	2500	V						8,29	5,31	3,40	2,36	1,73	1,33	0,85						
		hr						85	30	9,8	3,75	1,79	0,89	0,25						
180	3000	V						9,95	6,37	4,08	2,83	2,08	1,59	1,02	0,71					
		hr						120	42	13,8	5,3	2,53	1,25	0,35	0,15					
300	5000	V							10,62	6,79	4,72	3,47	2,65	1,70	1,18	0,87	0,66			
		hr							124,9	41,3	16,74	7,81	4,03	1,34	0,54	0,25	0,13			
600	10000	V								13,59	9,44	6,93	5,31	3,4	2,36	1,73	1,33			
		hr								161	65	30,2	15,6	5,16	2,09	0,97	0,5			
1200	20000	V													6,79	4,72	3,47	2,65		
		hr													20,1	8,13	3,8	1,95		
1800	30000	V														7,7	5,2	4,0		
		hr														18,07	8,39	4,32		
3000	50000	V														11,8	8,67	6,63		
		hr														49,5	23	11,8		
4500	75000	V															17,7	13	9,9	
		hr															110,5	51,3	26,4	
6000	100000	V																17,33	13,27	
		hr																90,6	46,6	



THE FLOW RESISTANCE MUST BE MULTIPLIED BY:

- 0.8 for stainless steel pipes
- 1.25 for slightly rusted steel pipes
- 1.7 for pipes with deposits that reduce the flow section
- 0.7 for aluminium pipes
- 1.3 for fibre-cement pipes

Hr = FLOW RESISTANCE (m/100 m OF PIPELINE)

V = WATER SPEED (m/sec)

FLOW RESISTANCE
TABLE OF FLOW RESISTANCE OF BENDS AND VALVES IN cm OF COLUMN OF WATER

WATER SPEED m/sec	SHARP BENDS 					SMOOTH BENDS 					STANDARD GATE VALVES	FOOT VALVES	CHECK VALVES
	a = 30°	a = 40°	a = 60°	a = 80°	a = 90°	$\frac{d}{R} = 0,4$	$\frac{d}{R} = 0,6$	$\frac{d}{R} = 0,8$	$\frac{d}{R} = 1$	$\frac{d}{R} = 1,5$			
0,10	0,03	0,04	0,05	0,07	0,08	0,007	0,008	0,01	0,0155	0,027	0,030	30	30
0,15	0,06	0,07	0,10	0,14	0,17	0,016	0,019	0,024	0,033	0,06	0,033	31	31
0,2	0,11	0,13	0,18	0,26	0,31	0,028	0,033	0,04	0,058	0,11	0,058	31	31
0,25	0,17	0,21	0,28	0,4	0,48	0,044	0,052	0,063	0,091	0,17	0,090	31	31
0,3	0,25	0,30	0,41	0,6	0,7	0,063	0,074	0,09	0,13	0,25	0,13	31	31
0,35	0,33	0,40	0,54	0,8	0,93	0,085	0,10	0,12	0,18	0,33	0,18	31	31
0,4	0,43	0,52	0,71	1,0	1,2	0,11	0,13	0,16	0,23	0,43	0,23	32	31
0,5	0,67	0,81	1,1	1,6	1,9	0,18	0,21	0,26	0,37	0,67	0,37	33	32
0,6	0,97	1,2	1,6	2,3	2,8	0,25	0,29	0,36	0,52	0,97	0,52	34	32
0,7	1,35	1,65	2,2	3,2	3,9	0,34	0,40	0,48	0,70	1,35	0,70	35	32
0,8	1,7	2,1	2,8	4,0	4,8	0,45	0,53	0,64	0,93	1,7	0,95	36	33
0,9	2,2	2,7	3,6	5,2	6,2	0,57	0,67	0,82	1,18	2,2	1,20	37	34
1,0	2,7	3,3	4,5	6,4	7,6	0,7	0,82	1,0	1,45	2,7	1,45	38	35
1,5	6,0	7,3	10	14	17	1,6	1,9	2,3	3,3	6	3,3	47	40
2,0	11	14	18	26	31	2,8	3,3	4,0	5,8	11	5,8	61	48
2,5	17	21	28	40	48	4,4	5,2	6,3	9,1	17	9,1	78	58
3,0	25	30	41	60	70	6,3	7,4	9	13	25	13	100	71
3,5	33	40	55	78	93	8,5	10	12	18	33	18	123	85
4,0	43	52	70	100	120	11	13	16	23	42	23	150	100
4,5	55	67	90	130	160	14	21	26	37	55	37	190	120
5,0	67	82	110	160	190	18	29	36	52	67	52	220	140

- 1) Flow resistance in bends is due to the contraction of the liquid threads resulting from the change of direction: the development of the bends must therefore be included in the length of the pipeline.
- 2) Flow resistance in valves and gates was determined on the basis of practical tests.

VOLUMETRIC CAPACITY

litres per minute l/min	cubic metres per hour m ³ /h	cubic feet per hour ft ³ /h	cubic feet per minute ft ³ /min	imp. gal. per minute imp. gal./min	US gal. per minute US gal./min
1,000	0,0600	2,1189	0,0353	0,2200	0,2640
16,6670	1,0000	35,3147	0,5886	3,6660	4,4030
0,4720	0,0283	1,0000	0,0167	0,1040	0,1250
28,3170	1,6990	60,0000	1,0000	6,2290	7,4800
4,5460	0,2728	9,6326	0,1605	1,0000	1,2010
3,7850	0,2271	8,0209	0,1337	0,8330	1,0000
0,1100	0,0066	0,2339	0,0039	0,0240	0,0290

PRESSURE AND HEAD

Newton per square metre N/m ²	kiloPascal kPa	bar bar	pound force per square inch psi	metre of water m H ₂ O	millimetre of mercury mm Hg
1,0000	0,0010	1 x 10 ⁵	1,45 x 10 ⁻⁴	1,02 x 10 ⁻⁴	0,0075
1.000,0000	1,0000	0,0100	0,1450	0,1020	7,5000
100.000,0000	100,0000	1,0000	14,5000	10,2000	750,1000
98.067,0000	98,0700	0,9810	14,2200	10,0000	735,6000
6.895,0000	6,8950	0,0690	1,0000	0,7030	51,7200
2.984,0000	2,9840	0,0300	0,4330	0,3050	22,4200
9.789,0000	9,7890	0,0980	1,4200	1,0000	73,4200
133,3000	0,1330	0,0013	0,0190	0,0140	1,0000
3.386,0000	3,3860	0,0338	0,4910	0,3450	25,4000

LENGTH

millimetre mm	centimetre cm	metre m	inch in	foot ft	yard yd
1,0000	0,1000	0,0010	0,0394	0,0033	0,0011
10,0000	1,0000	0,0100	0,3937	0,0328	0,0109
1000,0000	100,0000	1,0000	39,3701	3,2808	1,0936
25,4000	2,5400	0,0254	1,0000	0,0833	0,0278
304,8000	30,4800	3,0480	12,0000	1,0000	0,3333
914,4000	91,4400	0,9144	36,0000	3,0000	1,0000

VOLUME

cubic metre m ³	litre l	millilitre ml	imp. gallon imp. gal.	US gallon US gal	cubic foot ft ³
1,0000	1.000,0000	1 x 10 ⁶	220,0000	264,2000	35,3147
0,0010	1,0000	1.000,0000	0,2200	0,2642	0,0353
1 x 10 ⁻⁶	0,0010	1,0000	2,2 x 10 ⁻⁴	2,642 x 10 ⁻⁴	3,53 x 10 ⁻⁵
0,0045	4,5460	4.546,0000	1,0000	1,2010	0,1605
0,0038	3,7850	3.785,0000	0,8327	1,0000	0,1337
0,0283	28,3170	28.317,0000	6,2288	7,4805	1,0000

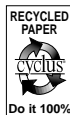
**ORGANIZZAZIONE COMMERCIALE ITALIA – ITALIAN SALES NETWORK**

BARI
70026 Modugno Bari
Via X Marzo, 110 P
Tel. 080 5327453 - 5353808
Fax: 080 5327926
e-mail: bari@lowara.ittind.com

BOLOGNA
40132 Bologna - Via Panigale, 74/C
Tel. 051 6415666
Fax: 051 6415527
e-mail: bologna@lowara.ittind.com

BRESCIA
25124 Brescia - Via Volta, 37
Tel. 030 3531909
Fax: 030 3534661
e-mail: brescia@lowara.ittind.com

CAGLIARI
09100 Cagliari - Via Dolcetta, 19
Tel. 070 287762 - 292192
Fax: 070 280946
e-mail: cagliari@lowara.ittind.com

CATANIA
95027 S. Gregorio - Catania
Via XX Settembre, 75
Tel. 095 7123226 - 7123987
Fax: 095 498902
e-mail: catania@lowara.ittind.com

CHIETI
66020 Sambuceto di S. Giovanni Teatino
Via Aldo Moro, 125
Tel. 085 4461360 - 4460231 - 4460449
Fax 085 4460630
e-mail: pescara@lowara.ittind.com

MILANO
20090 Trezzano sul Naviglio Milano
Via Goldoni, 29
Tel. 02 48464476 - Fax: 02 4451634
e-mail: milano@lowara.ittind.com

NAPOLI
80017 Melito di Napoli - Napoli
Corso Europa, 369 - Scala "A" int. 11-12
Tel. 081 7113065 - 7113631
Fax: 081 7115761
e-mail: napoli@lowara.ittind.com

PADOVA
35020 Albignasego - Via A. Volta, 56
Zona Mandriola
Tel. 049 8801110 - 8801408
Fax: 049 8801408
e-mail: bassano@lowara.ittind.com

PERUGIA
06100 Perugia
Via Settevalli, 133C, Torre 2 - 3° Piano
Centro Direzionale Piazza Settevalli
Tel. 075 5057126 - Fax: 075 5051242
e-mail: perugia@lowara.ittind.com

PISA
56025 Località Gello di Pontedera - Pisa
Via di Gello, 55
Tel. 0587 296264 - 296286
Fax: 0587 296410
e-mail: pisa@lowara.ittind.com

PORDENONE
33082 Azzano Decimo Pordenone
Viale 1° Maggio, 65/1 Area 53
Tel. 0434 633243 - Fax: 0434 632729
e-mail: pordenone@lowara.ittind.com

ROMA
00173 Roma - Via Frascineto, 8
Tel. 06 7235890 (2 linee)
Fax: 06 7234617
e-mail: roma@lowara.ittind.com

TORINO
Via Torre Pellice, 17 - 10156 Torino
Tel. 011 2979022 - 2979046
Fax: 011 2979001
e-mail: torino@lowara.ittind.com

VICENZA
36061 Bassano del Grappa - VI
Via Pigafetta, 6
Tel. 0424 566776 (R.A. 3 linee)
Fax: 0424 566773
e-mail: bassano@lowara.ittind.com

ORGANIZZAZIONE COMMERCIALE EUROPA – EUROPEAN SALES NETWORK

LOWARA DEUTSCHLAND GmbH
Biebigheimer Straße 12
63762 Großostheim - (OT Wenigumstadt) - D
Tel. 0 60 26 9 43 - 0
Fax: 0 60 26 9 43 - 2 10
e-mail: info.de@lowara.ittind.com
http://www.lowara.de

LOWARA FRANCE S.A.S.
BP 7311 - 37073 TOURS CEDEX 2 - F
Tel. (0033) 02 47 88 17 17
Fax: (0033) 02 47 88 17 00
e-mail: info.fr@lowara.ittind.com
http://www.lowara.fr

LOWARA NEDERLAND B.V.
POSTBUS 54 - 4180 BB Waardenburg
Tel. 0031 - (0)418 - 65 50 60
Fax: 0031 - (0)418 - 65 50 61
e-mail: info.nl@lowara.ittind.com
http://www.lowara.nl

LOWARA PORTUGAL, Lda
Praceta da Castanheira, 38
4475-019 Barca Portugal
Tel. 00351 22 9478550
Fax: 00351 22 9478570
e-mail: info.pt@lowara.ittind.com
http://www.lowara.pt

LOWARA UK Ltd. Main office
Millwey Rise Industrial Estate -
Axminster, Devon EX 13 5HU - GB
Tel. 01297 630200 - Fax: 01297 630270
e-mail: uksales@lowara.ittind.com
http://www.lowara.co.uk

LOWARA UK Ltd. Regional sales office
Unit 1, Byram Industrial Park - Low Street
Brotherton, Knottingley - West Yorkshire WF11 9HS
Tel. 01977 607267 - Fax 01977 607226
e-mail: salesuknorth@lowara.ittind.com
http://www.lowara.co.uk

LOWARA IRELAND Ltd.
59 Broomhill Drive - Tallaght Industrial Estate
Tallaght - DUBLIN 24 - EIRE
Tel. (1) 4520266 - Fax: (1) 4520725
e-mail: sales-ir@lowara.ittind.com
http://www.lowara.ie



LOWARA S.r.l. - 36075 Montecchio Maggiore - Vicenza - Italy - Tel. +39 0444/707111 - Telefax +39 0444/492166 - e-mail: mkt@lowara.ittind.com - http://www.lowara.com