

MINIBOX SERIES

PREFABRICATED COMPACT LIFTING STATIONS FOR DIRTY WATER

Minibox is a complete lifting station designed for removing domestic effluent excluding toilet waste where gravity drainage is not possible

SPECIFICATIONS

- It consists of an **85-litre** polyethylene **tank** housing a DOC electric pump and all its accessories.
- Installation is fast and easy, just connect the pipes and plug it in.
- Minibox can be installed above floor, buried underground or in concrete (to withstand passage of vehicles).
- Minibox is **equipped with a screen and sand filter basin** for the collection of water infiltration or runoff, as in the case of a garage ramp.
- An **optional watertight lid** (substituting the screen) can be installed for indoor use.
- The station includes:
 - **DOC submersible electric pump** equipped with a float for automatic operation.
 - 85-litre polyethylene **tank**.
 - 1 1/4" flexible tube equipped with a check valve; left- or right-hand connection.
 - Power **cord outlet**.
 - Three types of 40-mm diameter pipe inlets.
 - **Screens.**
 - **Basin** filled with sand and gravel to filter solid particles.
- The Minibox station can be equipped with a DOC3 (0.25 kW rating) or a **DOC7** pump (0.55 kW). For pump operating characteristics (delivery – head), see DOC pump section in this catalogue.
- **IP 68 protection.**



MINIBOX SERIES DIMENSIONS

MINIBOX

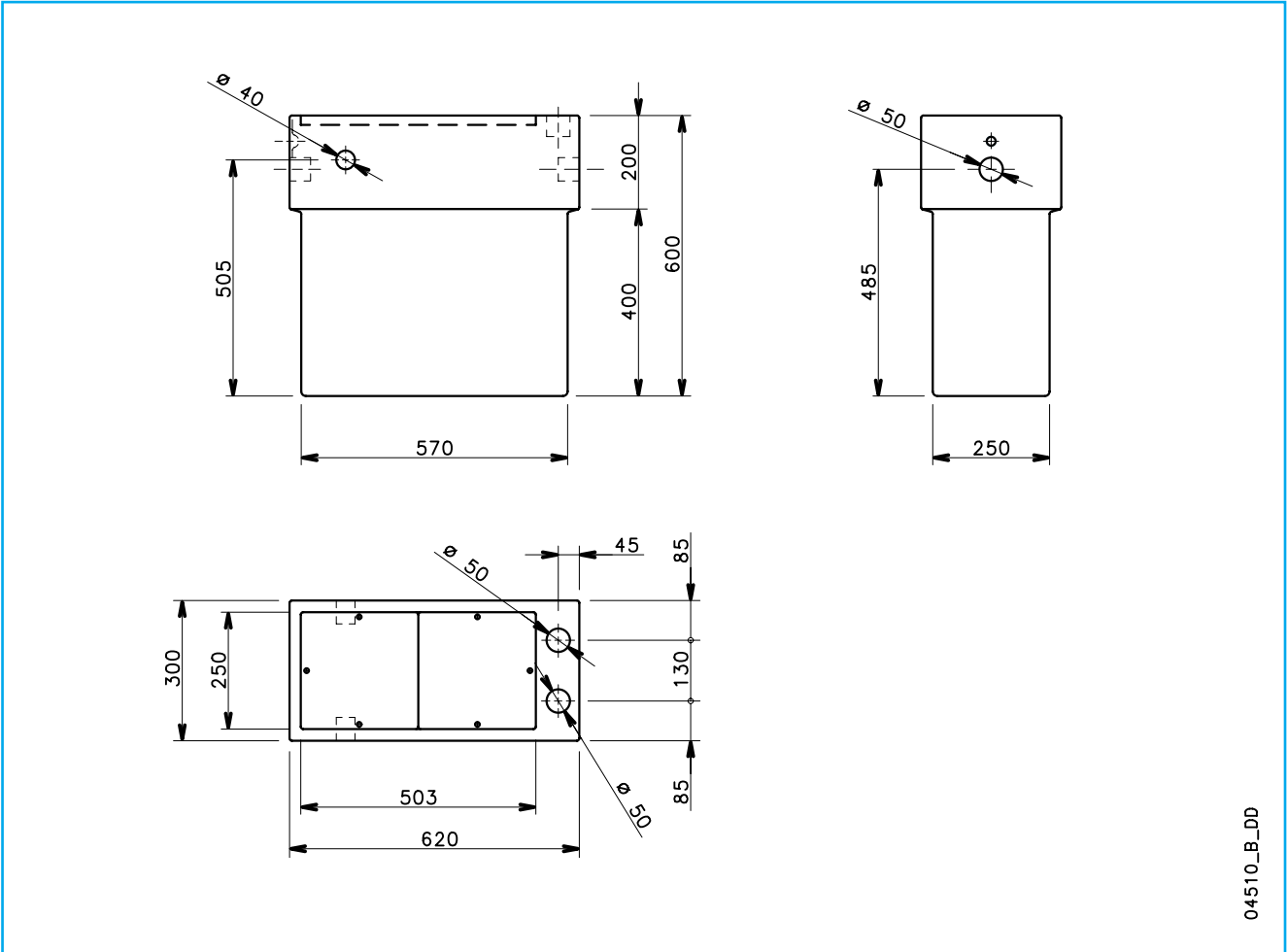

04510_B_DD

APPLICATION ILLUSTRATION

